

Harald Czekala¹, Thomas Rose¹, Martin Philipp¹, Oscar Hartogensis², Gerrit Maschwitz¹

¹: RPG Radiometer Physics GmbH, Birkenmaarstraße 10, 53340 Meckenheim, Germany

²: Wageningen University, Meteorology and Air Quality Group, PO Box 47, 6700 AA Wageningen, the Netherlands

RPG-MWSC-160

In 2014 Radiometer Physics GmbH (RPG) released the first commercially available microwave scintillometer RPG-MWSC-160. It was designed for combined operation with an optical Large Aperture Scintillometer (LAS) to observe sensible heat flux H and latent heat fluxes $L_V E$ at the same time.

Key Features

- High frequency (160.8 GHz, $\lambda=1.86$ mm) for sufficient co-spectrum with LAS
- Large aperture (300 mm) for small beam width (0.45° FWHM)
- Tuneable power level (max. >25 mW) allows path length between 500 m and 10 km
- Low weight (~10 kg)
- Low power consumption (~20 W)

Software

The RPG-MWSC-160 includes a software package for the combined operation of a MWSC/LAS scintillometer system. In combination with the integrated weather station Vaisala WXT 520 it provides the complete data processing chain from raw signals to heat fluxes.

Output data

- 500 Hz digital raw data for MWSC and LAS
- Housekeeping data
- (Co)variances of the combined system
- Structure parameters of refractive index C_n^2
- Sensible and latent heat fluxes H and $L_V E$

Data Processing

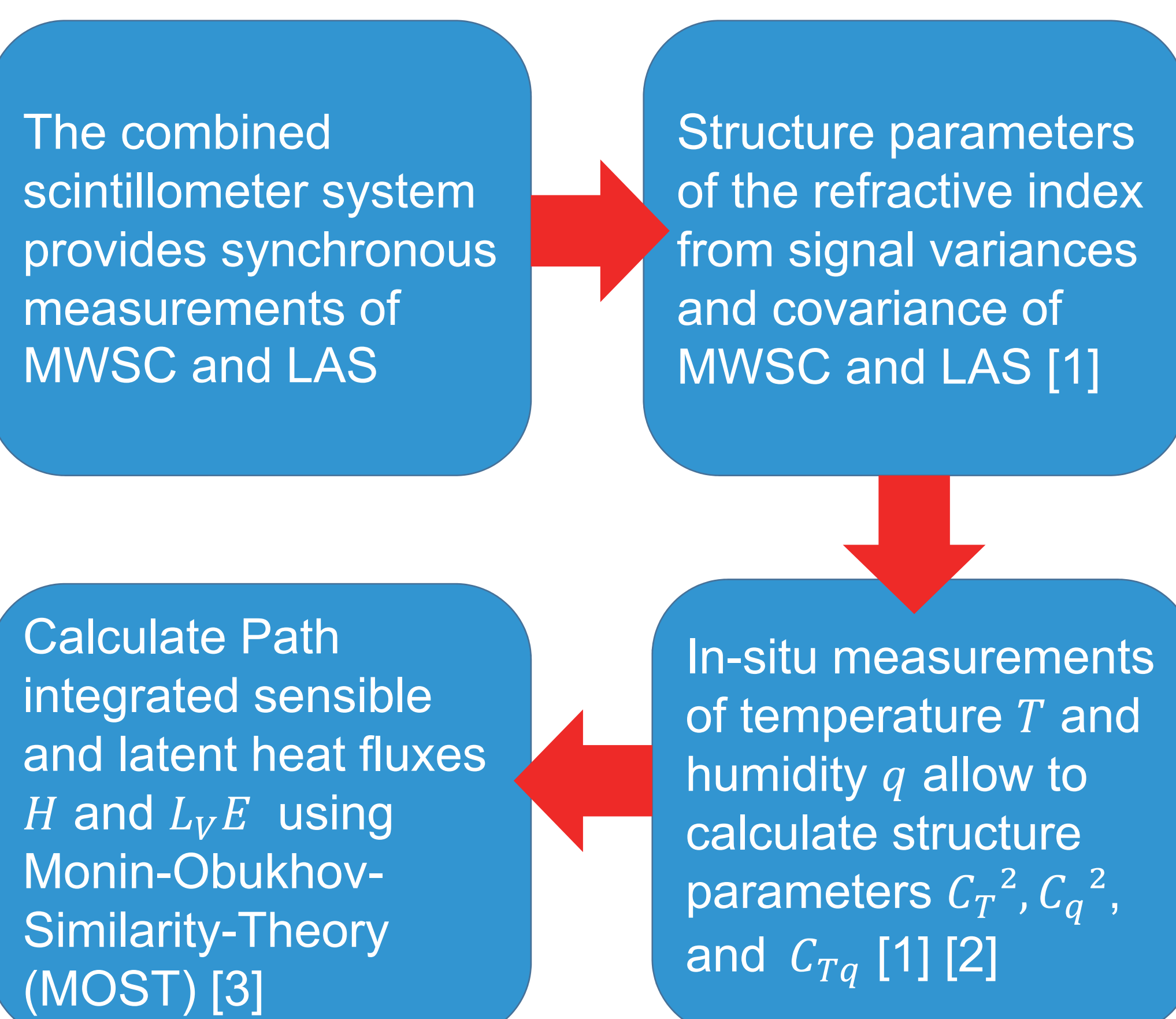

Applications

Measurements of the sensible heat flux H and evapotranspiration $L_V E$ are significant for:

- Irrigation and water management
- Forest fire warning
- Weather forecasting
- Radiation budget studies
- Hydrology



Design

The RPG-MWSC-160 uses hardware developments from space projects. The prototype instruments were developed by RPG and Wageningen University (The Netherlands) within the OMS (Optical and Microwave Scintillation) project.

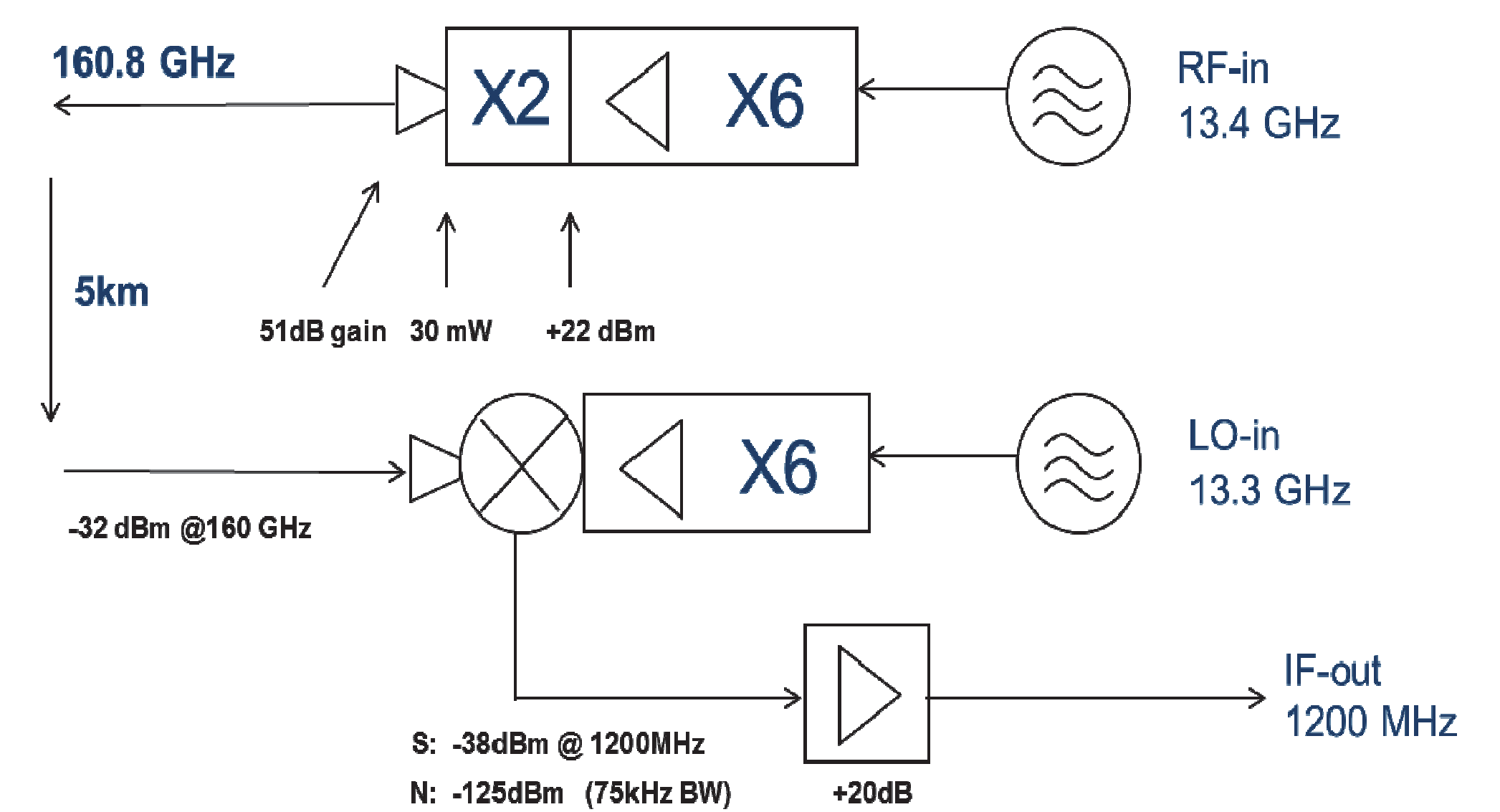
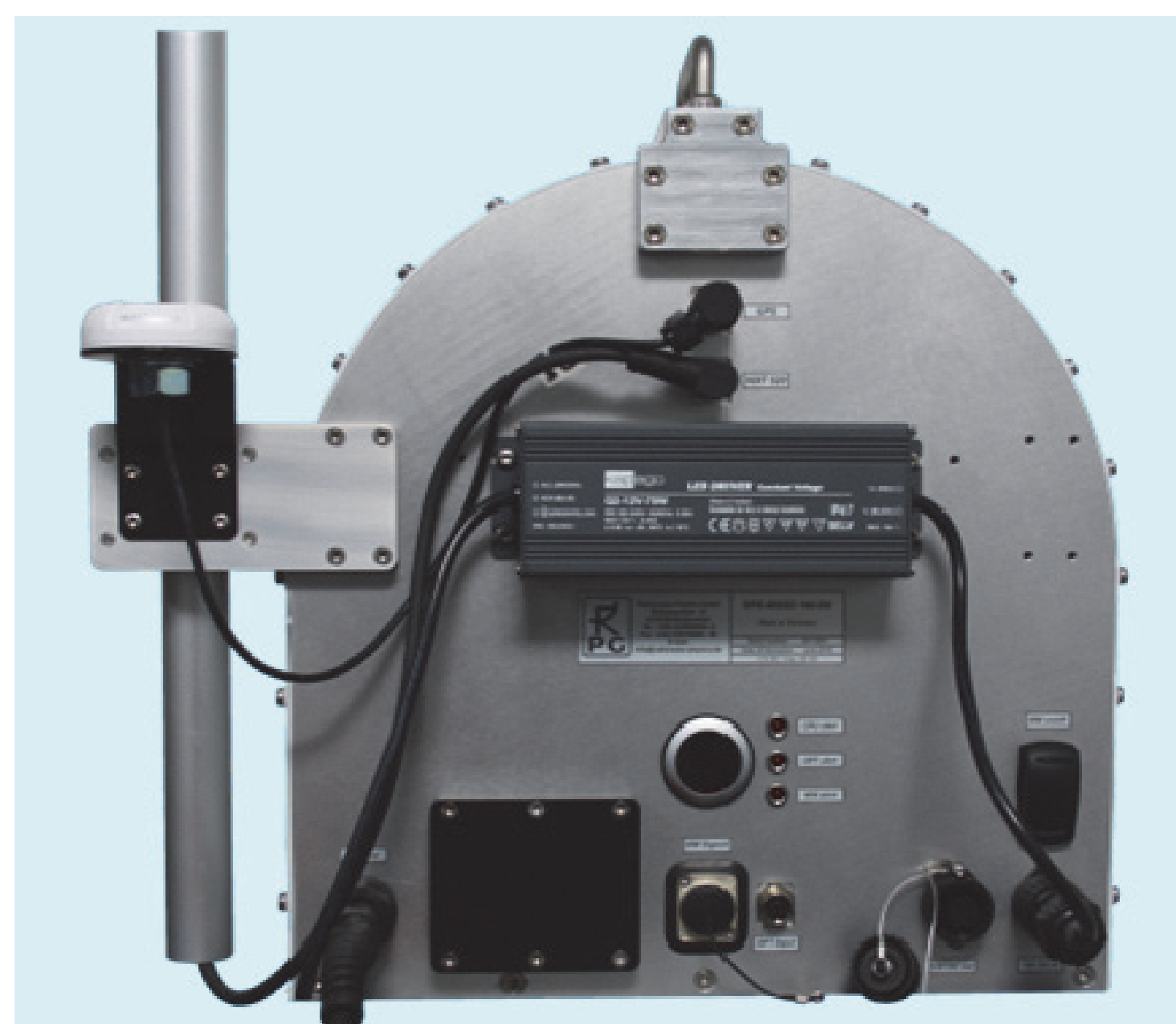

Measurements

The RPG-MWSC-160 has successfully been tested in combination with different LAS systems within two comprehensive field campaigns in Sonora (Mexico) and Lindenberg (Germany). The two campaigns cover two different applications: short path length / low observation height z (Mexico: $L = 880m, z = 2.75m$) over a homogeneous surface and long path length / high observation height (Lindenberg: $L = 4800m, z = 45m$) over a heterogeneous landscape.

Structure Parameters and Heat Fluxes

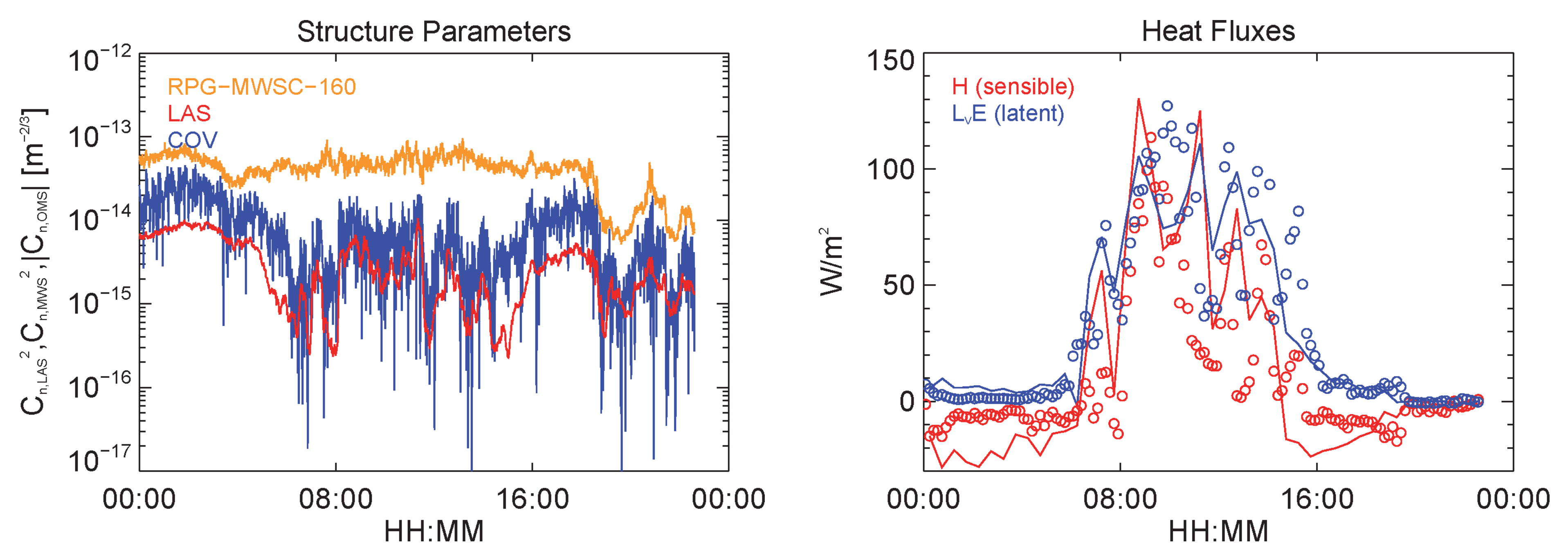

Measurement time series for a long path over heterogeneous landscape (September 8, 2013, Lindenberg, Germany). Left: refractive index structure parameters for RPG-MWSC-160, optical LAS, and for the signal covariance (COV) of both instruments (OMS method, Lüdi et al. [1]). Right: estimates of path integrated sensible heat flux H and latent heat flux $L_V E$. Circles give measurements from an Eddy Covariance station (EC).

References

- [1] A. Lüdi, F. Beyrich, and C. Mätzler, "Determination of the Turbulent Temperature–Humidity Correlation from Scintillometric Measurements," *Boundary-Layer Meteorol*, vol. 117, no. 3, pp. 525–550, Dec. 2005.
- [2] H. C. Ward, J. G. Evans, O. K. Hartogensis, A. F. Moene, H. A. R. De Bruin, and C. S. B. Grimmond, "A critical revision of the estimation of the latent heat flux from two-wavelength scintillometry," *Quarterly Journal of the Royal Meteorological Society*, p. n/a–n/a, 2013
- [3] D. Li, E. Bou-Zeid, and H. A. R. D. Bruin, "Monin–Obukhov Similarity Functions for the Structure Parameters of Temperature and Humidity," *Boundary-Layer Meteorol*, vol. 145, no. 1, pp. 45–67, Oct. 2012.