 RADIOMETER Physics GmbH	Technical Manual (standard radiometers)	Code:	RPG-MWR-STD-TM
		Date:	11.07.2011
		Issue:	01/00
		Pages:	45

Technical Instrument Manual

Description of Instrument Technology



Applicable for
 HATPRO, LHATPRO, TEMPRO, HUMPRO, LHUMPRO,
 LWP, LWP-U90, LWP-U72-82, LWP-90-150,
 Tau-225, Tau-225-350



Code:	RPG-MWR-STD-TM	Technical Manual (standard radiometers)	 RADIOMETER Physics GmbH
Date:	11.07.2011		
Issue:	01/00		
Page:	2 / 45		

Document Change Log

Date	Issue/Rev	Change
11.07.2011	00/01	Work
20.07.2011	01/00	Release

 RADIOMETER Physics PG GmbH	Technical Manual (standard radiometers)	Code:	RPG-MWR-STD-TM
		Date:	11.07.2011
		Issue:	01/00
		Page:	3 / 45

Table of Contents

Technical Instrument Manual	1
Document Change Log	2
Table of Contents	3
1 Scope of This Document	4
2. Instrument Hardware	4
2.1 Overview	4
2.2 Receivers	5
2.3 Detailed Description of Receiver Components	11
2.3.1 Antenna Performance	11
2.3.2 Noise Diodes	13
2.3.3 RF-Amplifiers	13
2.3.4 Bandpass Filters	13
2.3.5 Detector, Video Amplifier, ADC	13
2.4 Additional Sensors	14
2.5 Other Radiometer Details	15
2.6 Instrument Specifications	16
3 Advantages of Filterbank Systems over Sequentially Scanning Radiometers	29
3.1 Introduction	29
3.2 Tunable single channel vs. multiple parallel channels.....	30
3.3 How many channels are required to achieve the highest profiling accuracy?	31
3.4 Why is a high channel duty cycle important?	36
3.5 Why is a high precision important for a profiling radiometer?.....	36
3.6 Any other important radiometer features?.....	40
3.7 Summary	41
4 Electrical Connections	43
5 Radiometer dimensions	45

Code:	RPG-MWR-STD-TM
Date:	11.07.2011
Issue:	01/00
Page:	4 / 45

1 Scope of This Document

This document contains information about:

- Receiver technology and its advantages over other competing instrument concepts
- Radiometer optics
- Instrument specifications
- Wiring and geometrical dimensions

The technologies described in this document apply to single-polarization radiometers of HATPRO types (profiling radiometers RPG-XXXPRO series), LWP multi-channel radiometers (RPG-LWP-XXX series) and Tau/Tipping radiometers (RPG-Tau-XXX).

2. Instrument Hardware

2.1 Overview

Fig.3.1 shows a schematic drawing of the inner radiometer components. The following functional blocks can be identified:

- Receiver optics comprising a corrugated feedhorn (encapsulated in thermal insulation) for each frequency band and off axis paraboloid (scanning mirror)
- Two receiver units (Receiver 1, Receiver 2)
- The ambient temperature calibration target
- The internal scanning mechanism
- The instrument electronics sections
- Data acquisition system

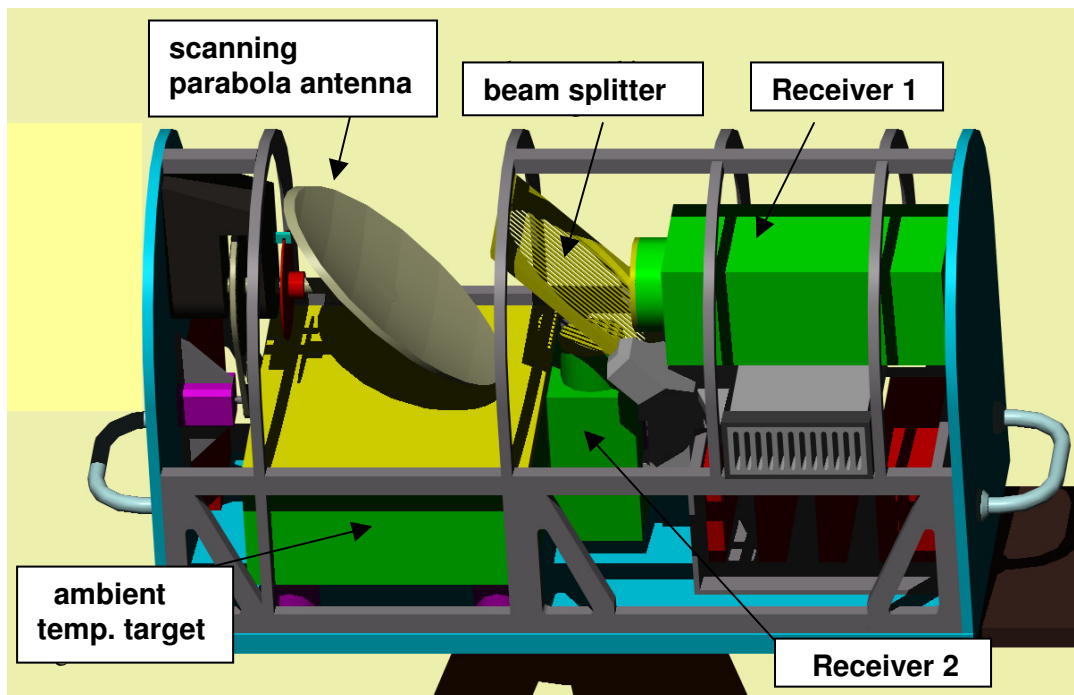

Fig. 2.1: Schematic internal structure of un-polarized RPG radiometers.

The optical section is optimized for microwave beams with less than -30 dB side-lobe level. It avoids dielectric lossy elements (like lenses) which helps to reduce standing wave problems within the quasi-optics and improves the radiometer stability and calibration accuracy. The corrugated feed horn offers a low cross polarization level and a rotationally symmetric beam pattern.

The beams of the two receivers are superimposed by a polarizer wire grid and reflected via an off-axis parabola mirror (Fig.2.1). This parabola antenna is also used for elevation scanning and calibration. The ambient temperature precision calibration target is located below the scanning mirror while an external target is needed as a liquid nitrogen cooled calibration standard for absolute calibration.

The receivers are integrated with their feed horns and are thermally insulated to achieve a high thermal stability.

2.2 Receivers

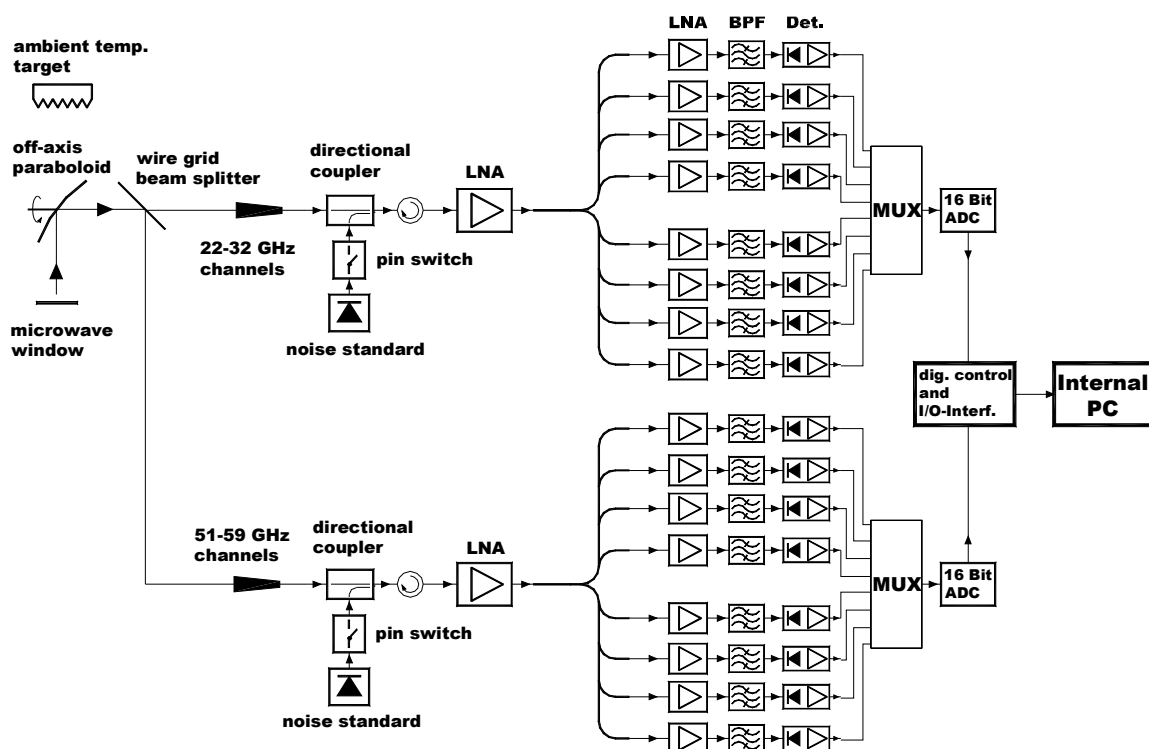

Fig.2.2a: Example of RPG-HATPRO schematic receiver layout. Both radiometers are direct detection systems without the need for local oscillators and mixers.

The receiver concept is motivated by the following design goals:

- The design of the receiver section focuses on maximum thermal and electrical stability, a compact layout with a minimum of connectors and thermally drifting components, an integrated RF design, low power consumption and weight.

- The receivers comprise a reliable calibration system with precision secondary standards. The accuracy of calibration target temperature sensors and the minimization of thermal gradients are critical items to achieve an absolute brightness temperature accuracy of 1K.
- In addition to the measurement of humidity and temperature profiles it is desirable to design a system with fast sampling rates to derive quantities as LWP (Liquid Water Path) and IWV (Integrated Water Vapour). Since LWP is a rapidly varying parameter when clouds are passing the field of view, a high temporal resolution in the order of seconds is required to resolve the variability of LWP. Thus the water vapour line is scanned as fast as possible (1 second sampling rate).

Fig.2.2a shows an example of a RPG-HATPRO receiver system schematic. At the receiver inputs a directional coupler allows for the injection of a precision noise signal generated by an on/off switching calibrated noise source. This noise signal is used to determine system nonlinearities (four point method) and system noise temperature drifts during measurements. A 60 dB low noise amplifier (LNA) boosts the input signal before it is split into 8 branches (only 7 are currently used). The splitters implement waveguide bandpass filters (BPF) with bandwidths and centre frequencies listed in table 3.1a.

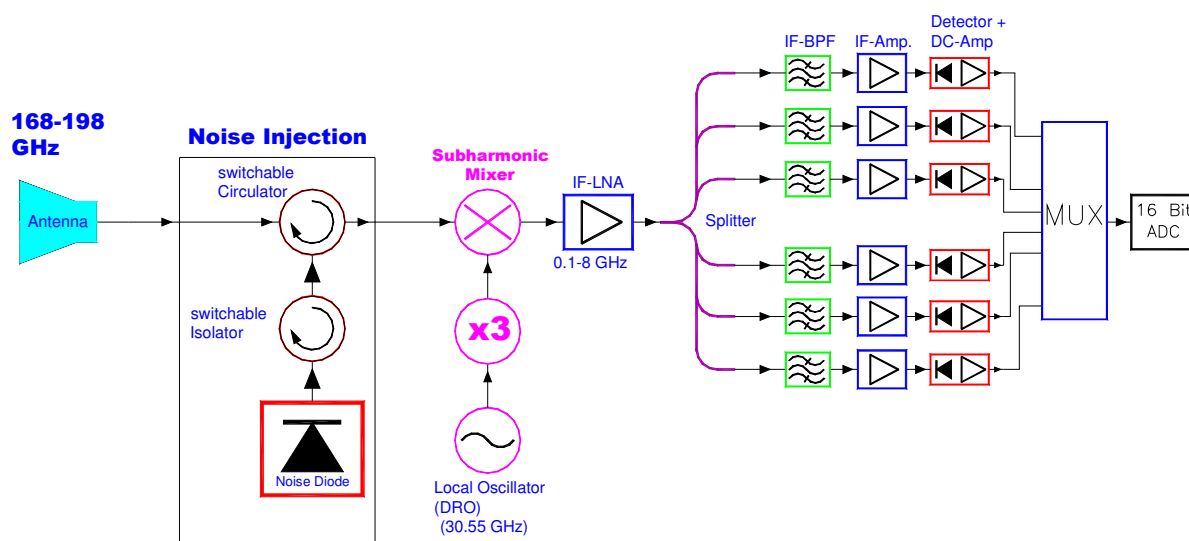

Fig.2.2b: Example of RPG-LHATPRO 183 GHz water vapour radiometer schematic receiver layout. The system is equipped with a new 160-200 GHz calibration noise source, allowing for a full internal auto-calibration without the need for heated or cooled calibration targets.

f _c [GHz]	22.24	23.04	23.84	25.44	26.24	27.84	31.40	51.26	52.28	53.86	54.94	56.66	57.30	58.00
b[MHz]	230	230	230	230	230	230	230	230	230	230	230	600	1000	2000

Table 2.1a: RPG-HATPRO channel centre frequencies and corresponding bandwidths.

Fig.2.2b shows a schematic of a heterodyne detection system, the RPG-LHATPRO 183 GHz water vapour line receiver system. At the receiver inputs a circulator allows for the injection of a precision noise signal generated by an on/off switching calibrated noise source. The

noise source generates more than 7000 K equivalent noise temperature and can be used with a directional coupler of -15 dB coupling factor.

A low noise RPG sub-harmonic mixer (SHM-183-S1F-19) with a typical noise temperature of 400-500 K provides a wide IF-band of 0.2 to 20 GHz with only small sensitivity variations across the whole band (see Fig.2.2c). An ultra-low IF amplifier boosts the SHM output and feeds a 6 way splitter to separate the 6 parallel channels. 6 individual BPFs (band-pass filters) with different bandwidths for sensitivity improvement, followed by IF boosters and individual detector units for each channel, form the parallel filter bank architecture of this receiver. The band-pass filters' centre frequencies and bandwidths are listed in table 2.1b.

The 183 GHz water vapour receiver is a DSB (double sideband) heterodyne radiometer with the LO (local oscillator) tuned to the line centre at 183.31 GHz. The mixer's lower / upper sideband response has been characterized by using a Rhode & Schwarz network analyzer + frequency extension for the 170-220 GHz range. Fig.3.2.d shows the USB response of the system calculated from the DSB measurement using the sideband response weighting characteristic.

The RPG-LHATPRO is designed for ultra-low humidity sites ($IWV < 4.0 \text{ kg/m}^2$) like high altitudes or Arctic / Antarctic areas where the highest IF channel at 7.5 GHz is sufficient for an accurate LWP detection (accuracy 20 g/m^2). RPG offers a 183 GHz receiver version with an additional 14 GHz IF channel for improved LWP detection at sites with IWV levels well above 1.0 kg/m^2 .



183 GHz SHM RPG-SHM-183-S1F-19 (167-200 GHz)

Mixer Noise Temperature (DSB), LO: 91.5 GHz

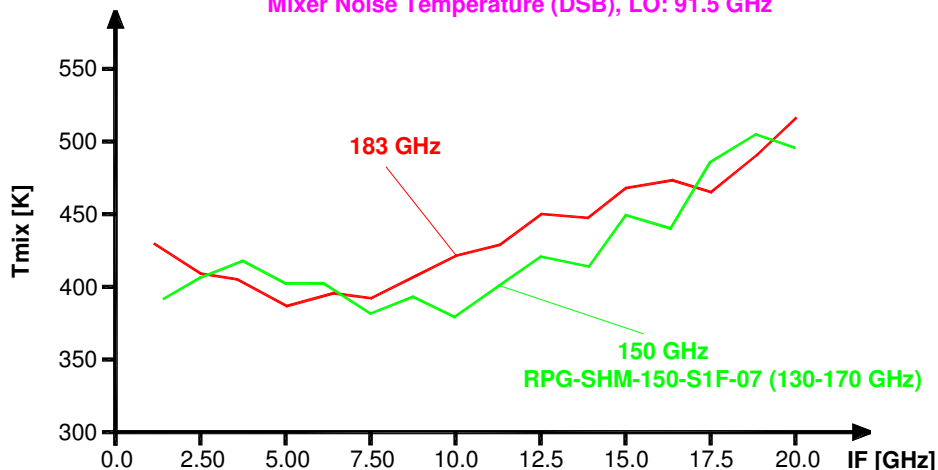

Fig.2.2c: RPG-LHATPRO 183 GHz SHM performance over IF bandwidth.

f_c [GHz]	183.91	184.81	185.81	186.81	188.31	190.81	51.26	52.28	53.86	54.94	56.66	57.30	58.00
b [MHz]	200	200	200	200	400	500	230	230	230	230	600	1000	2000

Table 2.1b: RPG-LHATPRO receiver centre frequencies and channel bandwidths.

The RPG-LHATPRO's humidity profiling capabilities are by far better than those of the 22 GHz water vapour line based RPG-HATPRO instruments (see Measurement and Deployment Manual).

Another class of RPG instruments is using an additional calibration standard, called Dicke Switch (DS). An example of this type is the RPG-150-90 radiometer:

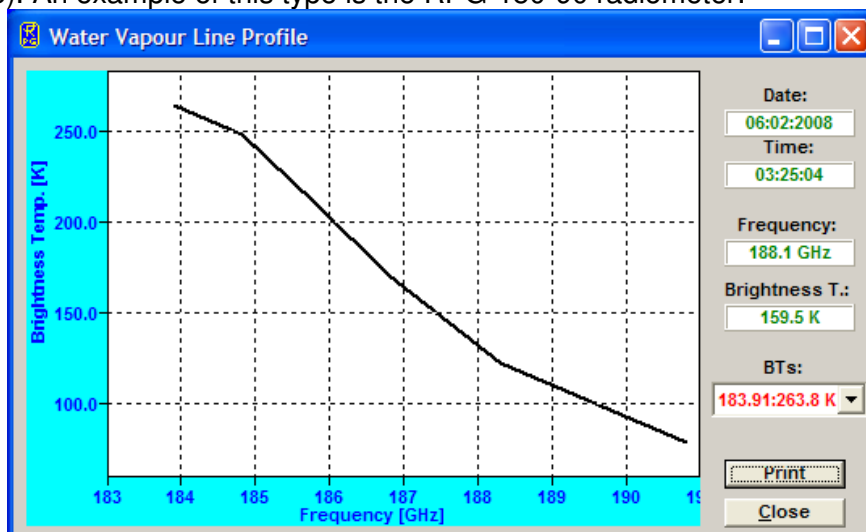
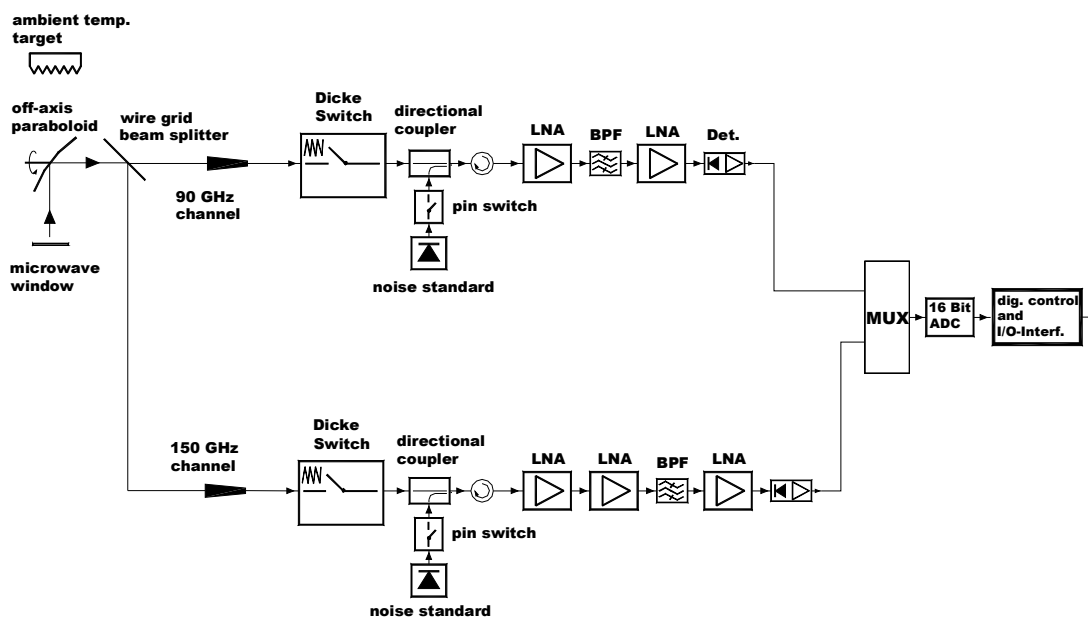

Fig.2.2d: RPG-LHATPRO 183 GHz water vapour line observed on Pic du Midi (2977 m asl) in the French Pyrenees (courtesy of CNRS, Laboratoire d'Aerologie, Observatoire Midi-Pyrenees).



 RADIOMETER Physics GmbH	Technical Manual (standard radiometers)	Code:	RPG-MWR-STD-TM
		Date:	11.07.2011
		Issue:	01/00
		Page:	9 / 45

Fig.2.2e: RPG-150-90 precision LWP radiometer receiver layout. The system is equipped with a full set of calibration standards (noise diode + Dicke switch).

The Dicke switch in ON position terminates the receiver inputs with an absorber which is stabilized at ambient temperature. Therefore it can be used as a calibration target (instead of the quasi-optical built-in target). The advantage is that the radiometer can continuously perform a full auto-calibration while pointing to the scene direction. The elevation mirror does not have to be moved to a target away from the scene. This is ideal for the continuous (interruption free) observation of LWP time series with high temporal resolution.

In OFF position the DS is passing the scene signal to the receiver input. A very low DS transmission loss is important in order to remain a high receiver sensitivity. Typical DS transmission losses are in the order of 0.5 to 1.0 dB.

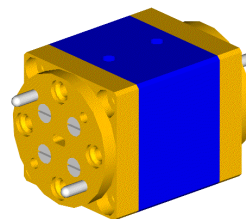

Fig.2.2f: Left: Narrow band 90 GHz y-junction Dicke Switch (transmission loss 0.6 dB, right: Full W-band Faraday Dicke Switch (transmission loss 1.0 dB).

Each channel has its own detector diode. This allows for a parallel detection and integration of all HATPRO / LHATPRO channels which implies a fast scanning of the water vapour and oxygen lines. The detector outputs are amplified by an ultra low drift operational amplifier chain and multiplexed to a 16 bit AD converter.

The HATPRO receivers (and LHATPRO temperature profiler) are based on the direct detection technique without using mixers and local oscillators for signal down conversion. Instead the input signal is directly amplified, filtered and detected. The advantages over a heterodyne system are the following:

- No mixers and local oscillators required (cost reduction)
- Local oscillator drifts in amplitude and frequency avoided (stability improvement)
- Mixer sideband filtering not required (cost reduction)
- Reduced sensitivity to interfering external signals (mobile phones etc.) due to avoidance of frequency down conversion

The filter bank concept (parallel channel layout) has the following advantages over sequentially scanning radiometers (e.g. synthesizer sweeping receivers, spectrum analysers):

- Simultaneous measurements of all frequency channels
- Much higher temporal resolution for all products (1 second)

Code:	RPG-MWR-STD-TM
Date:	11.07.2011
Issue:	01/00
Page:	10 / 45

Technical Manual (standard radiometers)



- 7 times faster calibration procedures
- Individual channel bandwidth selection (important for boundary layer temp. profiling)

Fig.2.3 shows the compact realization of the temperature profiler receiver/feedhorn combination. A high integration level is achieved due to the use of state of the art low noise amplifier MMICs for the 20-30 GHz and 50-60 GHz ranges, which offer superior sensitivity performance compared to direct mixers.

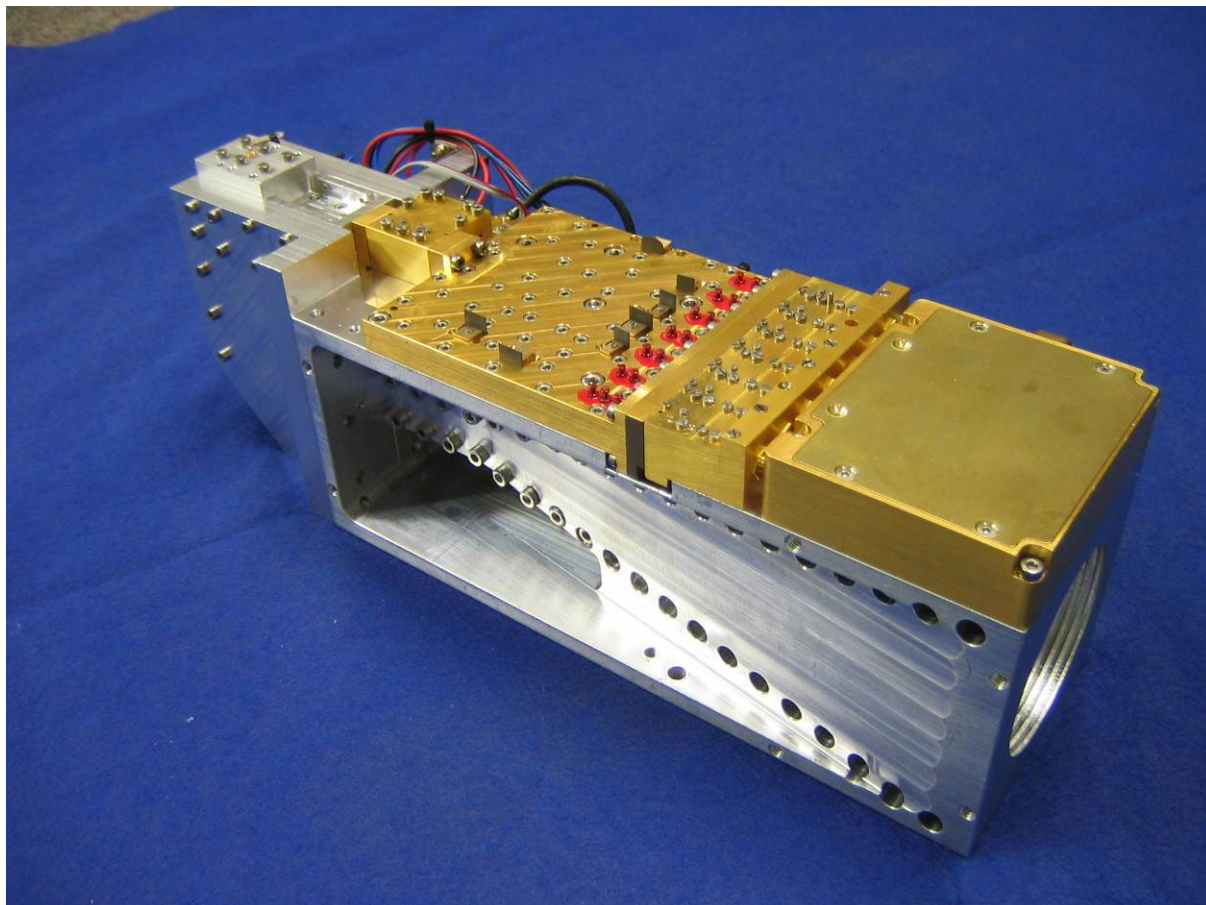



Fig.2.3: Temperature profiling direct detection filter bank receiver mounted to the 50-60 GHz corrugated feedhorn. Receiver size: 72 x 200 x 15 mm³.

The two independent filter banks allow a completely parallel operation of both profilers which reduces measurement time of humidity and temperature profiles to a minimum. It has been shown in field campaigns that the temporal resolution of such profile measurements should be in the order of 30 to 60 seconds per cycle because water vapour can be quite variable (e.g. cloud forming convection cells). The filter bank design gives superior performance compared to synthesizer controlled receivers because the spectrum is acquired much faster (in one step instead of sequentially switching the channels by a synthesizer). The measurement duty cycle is 100% which is also beneficial for all calibration procedures. A gain calibration takes only 20 seconds with a filter bank receiver but 140 (!) seconds with a synthesizer controlled radiometer.

The total power consumption of both receiver packages is < 6 Watts. This includes biasing of RF- and DC- amplifiers, noise diodes, ADCs and digital control circuits. The low consumption

 RADIOMETER Physics GmbH	Technical Manual (standard radiometers)	Code:	RPG-MWR-STD-TM
		Date:	11.07.2011
		Issue:	01/00
		Page:	11 / 45

simplifies the thermal receiver stabilization with an accuracy of < 0.03 K over the whole operating temperature range (-45°C to $+50^{\circ}\text{C}$).

2.3 Detailed Description of Receiver Components

2.3.1 Antenna Performance

To meet the optical requirements of minimum reflection losses and compactness a corrugated feedhorn is an optimal choice. It offers a wide bandwidth, low cross polarization level and a rotationally symmetric beam. Corrugated feedhorns can be designed for a great variety of beam parameters. The horn should be as small as possible to reduce weight and costs.

In order to generate a beam with the desired divergence (e.g. 2.5° - 3.5° HPBW in the case of a humidity profiling radiometer operating on the 22.24 GHz water vapour line) a focussing element is needed. The use of a lens in front of the feedhorn is not ideal since it introduces reflections at the dielectric surfaces and losses inside the dielectric. An off axis parabola antenna has negligible losses and can simultaneously be used to scan the beams in elevation.

The side-lobe levels produced by the feedhorn / parabola system should be below -30 dBc so that brightness temperature errors can be kept < 0.2 K in the case that the side-lobe crosses the sun. A HPBW close to 3° is a compromise with respect to spatial resolution on one hand and to the design of a compact, portable instrument for field campaigns on the other hand.

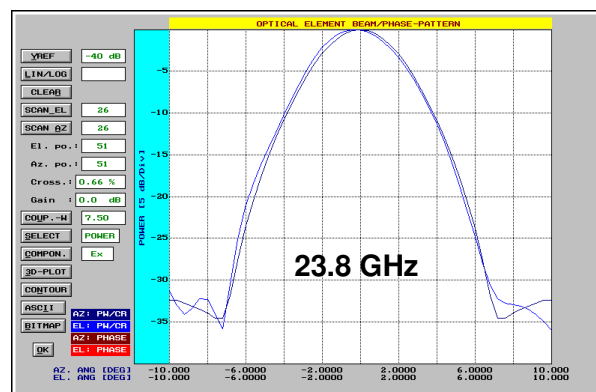
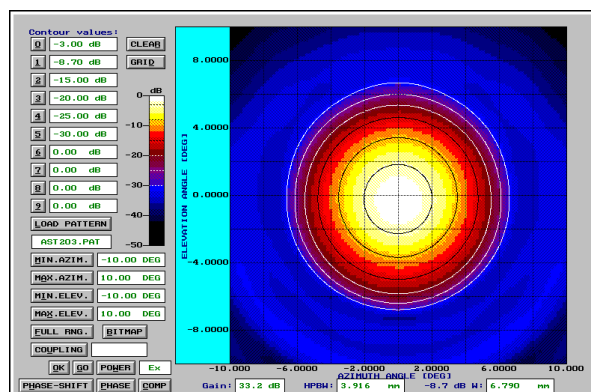

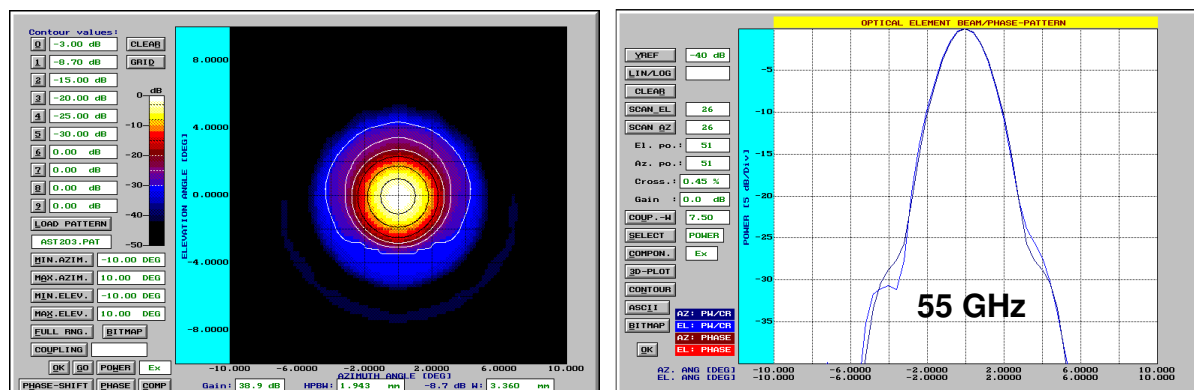

Fig.2.4: Left: 2d amplitude distributions of the parabola / corrugated feed @ 23.8 and 55 GHz. Right: H-and E-plane cuts.

The parabola antenna covers a projected diameter of 250 mm.

Frequency [GHz]	22-31	51-59
sidelobe level [dBc]	<-30	<-50
directivity [dB]	33.2	39.8
HPBW [°]	3.3-3.7	1.8-2.2

Table 2.2a: Optical antenna performance of corrugated feed / off-axis parabola system for the RPG-HATPRO, RPG-HUMPRO, RPG-TEMPRO radiometers.

Frequency [GHz]	90	150
sidelobe level [dBc]	<-40	<-50
directivity [dB]	40	40
HPBW [°]	1.6	1.6

Table 2.2.b: Optical antenna performance for the RPG-LWP-150-90.

Frequency [GHz]	72	82
sidelobe level [dBc]	<-40	<-40
directivity [dB]	40	40
HPBW [°]	1.6	1.6

Table 2.2.c: Optical antenna performance for the RPG-LWP-U72-82.

Frequency [GHz]	183	225 / 340
sidelobe level [dBc]	<-40	<-50
directivity [dB]	41	41
HPBW [°]	1.3	1.3

Table 2.2.c: Optical antenna performance for the RPG-LHATPRO, RPG-LHUMPRO, RPG-TP-225 and RPG-TP-340.

 RADIOMETER Physics GmbH	Technical Manual (standard radiometers)	Code:	RPG-MWR-STD-TM
		Date:	11.07.2011
		Issue:	01/00
		Page:	13 / 45

2.3.2 Noise Diodes

The noise diode is one of the most critical receiver components because the system's brightness temperature critically depends on the calibration reliability. For this reason a careful circuit design and component selection is essential. The noise diode meets MIL-STD202, is hermetically sealed and has been burned in for 170 hours in order to achieve a precisely constant symmetrical white Gaussian noise level. The waveguide circuit layout including a -20 dB directional coupler guarantees the required mechanical stability needed to operate the calibration standard for several month without recalibration. The thermally stabilized diode is biased by a self adjusting voltage/current source. The directional coupler offers an isolation of >30 dB to the input signal path so that the noise injection does not significantly affect the antenna temperature. The equivalent noise temperature injected by the noise diode is in the range 150K-300K at the isolator input.

2.3.3 RF-Amplifiers

The advances in MMIC technology during recent years have led to low noise amplifiers up to 100 GHz. A key feature of this technology is the possibility of integrating the receiver into a compact planar structure without the need for bulky waveguide designs. In the frequency range between 50 and 60 GHz noise figures of 2.5 dB and bandwidth of 10 GHz are available. Each amplifier comprises a thermal compensation circuit to reduce gain drifts. The amplifier outputs are equipped with isolators to ensure a proper matching between successive stages. Assuming a 2.5 dB noise figure for the first amplifier and additional 2.0 dB for losses in the feedhorn, isolator and directional coupler results in a system noise temperature of 750 K (60 GHz, SSB). With a scene temperature of 300 K the overall RMS noise, assuming a 230 MHz bandwidth and 1 second integration time) is 0.15 K.

2.3.4 Bandpass Filters

The receiver channel bandwidths are determined by waveguide bandpass filters integrated into the filterbank signal splitter section. The 3 pole Chebychev-type filters with 0.2 dB bandpass ripple and 0.5 dB typical transmission loss have a cutoff slope of 30 dB/200 MHz. The high Q design (0.5% rel. bandwidth) is realized by waveguide cavity resonators. The centre frequency of these filters is adjusted to an accuracy of 150 kHz by measuring the channel response through the complete receiver chain at the detector output.

2.3.5 Detector, Video Amplifier, ADC

The zero bias highly doped GaAs Schottky detector diodes can handle frequencies up to 110 GHz with a virtually flat detection sensitivity from 10 GHz to 35 GHz. In addition, the detector diode offers superior thermal stability when compared to silicon zero bias Schottky diodes. The rectified DC-signal enters an ultra stable OP-Amp circuit with internal analogue integrator. The utilized OP-Amps offer a thermal drift stability of 0.03 $\mu\text{V}/^\circ\text{C}$ which is roughly equivalent to a brightness temperature drift of 10 mK/ $^\circ\text{C}$ assuming a broadband detector with a sensitivity of 1 mV/ μW . The long term stability is 0.2 $\mu\text{V}/\text{month}$.

Code:	RPG-MWR-STD-TM
Date:	11.07.2011
Issue:	01/00
Page:	14 / 45

The 16 bit AD-converter is part of the video amplifier's circuit board to avoid noise from connecting cable pickup. It is optimized for low power dissipation (10 mW) and the high resolution makes a variable offset- and gain-control of the video amplifier superfluous. The detector, video amplifier and ADC are integrated within a single hermetically shielded unit which is part of the receiver block (thermally stabilized to an accuracy of <math><0.03\text{K}</math>).

2.4 Additional Sensors

Apart from the microwave receivers the RPG profiling radiometers are equipped with the following additional sensors:

Environmental Temperature Sensor: Accuracy: $\pm 0.5^\circ\text{C}$, used to estimate T_{mr} (mean atmospheric temperature) needed for sky tipping calibration procedure.

Humidity Sensor: Accuracy: $\pm 5\%$ relative humidity, used to estimate T_{mr} (mean atmospheric temperature) needed for sky tipping calibration procedure.

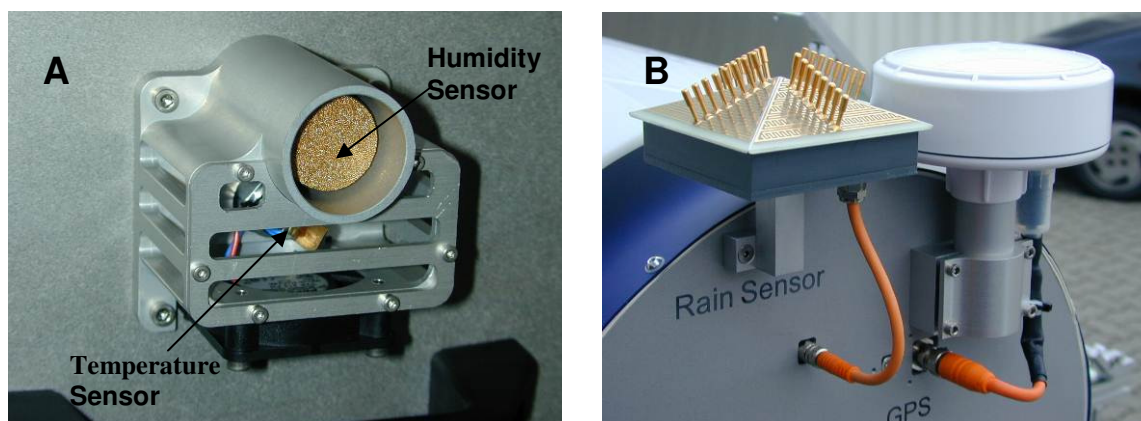

Fig.2.5: External Sensors: A) humidity and temperature sensors, B) rain sensor and GPS receiver.

Barometric Pressure Sensor: Accuracy: ± 1 mbar, used to estimate T_{mr} (mean atmospheric temperature) needed for sky tipping calibration procedure and for the determination of liquid nitrogen boiling temperature (absolute calibration).

Rain Sensor: The rain flag of this sensor is used for all measurements as additional information and for operating the dew blower fan speed.

GPS-Receiver: Receives UTC time and instrument position. Used as time standard for exact temporal synchronization.

Infrared Radiometer (optional): This instrument is attached to the radiometer housing. The interface connection and power supply is provided by the radiometer so that a later upgrade is possible. The operating software supports the use of an infrared radiometer including retrieval development and simple monitoring features.

All meteorological sensors are calibrated without the need for further recalibration. The chemically inert humidity sensor is protected by a sintered and gold plated metal dust filter. The temperature sensor is permanently exposed to a flow of air generated by a fan below the sensor cage to reduce sensor errors caused by self-heating.

An infrared radiometer, when added to the radiometer system, improves the accuracy of humidity profiling and allows for a rough estimate for liquid water profiles and cloud base height.

 RADIOMETER Physics GmbH	Technical Manual (standard radiometers)	Code:	RPG-MWR-STD-TM
		Date:	11.07.2011
		Issue:	01/00
		Page:	15 / 45

2.5 Other Radiometer Details

In order to fulfil the requirement of low maintenance regarding absolute calibrations, the instrument is equipped with a two-stage thermal control system for both receivers with an accuracy of ± 0.05 K over the full operating temperature range. Due to this extraordinary high stability the receivers can run freely without any calibration (not even the automatic gain calibration) for 20 minutes while maintaining an absolute brightness temperature accuracy of ± 0.5 K. Each receiver is equipped with a precision noise standard (long term stability) at its signal input which replaces the external cold target in the internal absolute calibration procedure.



Fig.2.6: Extensive insulation of all receiver components in combination with a two-stage stabilisation system allows to achieve a thermal receiver stability of 30 mK over the full operating temperature range.

The microwave window is protected from rain drops and dew formation by a powerful dew blower system. A rain detector and a software defined humidity threshold control the dew blower fan speed. Dew formation on the window can cause significant errors (several K) in the measurement of brightness temperatures.

The system performs many automatic tasks like data interfacing with the external host, data acquisition of all housekeeping channels and detector signals, controlling of elevation stepper, backup storage of measurement data, automatic and absolute calibration procedures, retrieval calculations etc. These tasks are handled by a build in embedded PC with 1.0 GByte disk on module (DOM) for data storage. This PC is designed for operating

Code:	RPG-MWR-STD-TM
Date:	11.07.2011
Issue:	01/00
Page:	16 / 45

Technical Manual (standard radiometers)



temperatures from -30°C to 60°C and is therefore ideal for remote application. The software running on this PC can easily be updated by a password protected file transfer procedure between host and embedded PC.

The host computer software operates under Windows NT4.0®, Windows 2000®, Windows XP®, Windows Vista® and Windows 7®. A complete host software description is given in chapter 5.

2.6 Instrument Specifications

RPG-HATPRO (tropospheric humidity / temperature profiler):

Parameter	Specification
Humidity profile performance	Vertical resolution: 200 m (range 0-2000 m) 400 m (range 2000-5000 m), 800 m (range 5000-10000 m) Accuracy: 0.4 g/m ³ RMS (absolute hum.) 5% RMS (rel. humidity)
Temperature profile performance	Vertical resolution: BL-Mode: 30 m -50 m (range 0-1200 m) Z-Mode: 200 m (range 1200-5000 m) 400 m (range 5000-10000 m) Accuracy: 0.25 K RMS (range 0-500 m) 0.50 K RMS (range 500-1200 m) 0.75 K RMS (range 1200-4000 m) 1.00 K RMS (range 4000-10000 m)
Liquid water profile performance (only with IR radiometer option)	Vertical resolution: 250 m (range 0-2000 m) 300 m (range 2000-5000 m), 500 m (range 5000-10000 m) Accuracy: cloud base height: 50 m (range 0-300 m) 100 m (range 300-1000 m) 200 m (range 1000-3000 m) 400 m (range 3000-5000 m) 600 m (range 5000-10000 m) density: 0.3 g/m ³ RMS Threshold: 50 g/m ² LWP
IR radiometer option	9.2-10.6 μm band, accuracy 1 K, noise: 0.2 K RMS
LWP	Accuracy: +/- 20 g/m ² Noise: 2 g/m ² RMS
IWV	Accuracy: +/-0.2 kg/m ² RMS Noise: 0.05 kg/m ² RMS
Full sky IWV and LWP maps (only with azimuth positioner option)	350 points in 6 minutes rapid scanning

 RADIOMETER Physics GmbH	Technical Manual (standard radiometers)	Code:	RPG-MWR-STD-TM
		Date:	11.07.2011
		Issue:	01/00
		Page:	17 / 45

Satellite tracking mode (only with azimuth positioner option)	Determines wet/dry delay and atmospheric attenuation along line of sight for all visible GPS / Galileo satellites in a single scan (2 minutes)
Channel center frequencies	K-Band: 22.24 GHz, 23.04 GHz, 23.84 GHz, 25.44 GHz, 26.24 GHz, 27.84 GHz, 31.4 GHz V-Band: 51.26 GHz, 52.28 GHz, 53.86 GHz, 54.94 GHz, 56.66 GHz, 57.3 GHz, 58.0 GHz
Channel bandwidth	2000 MHz @ 58.0 GHz, 1000 MHz @ 57.3 GHz, 600 MHz @ 56.66 GHz, 230 MHz @ all other frequencies
System noise temperatures	<400 K for 22-31 GHz profiler, <700 K for 51.4-58.0 GHz profiler
Radiometric resolution	K-Band: 0.10 K RMS, V-Band: 0.20 K RMS @ 1.0 sec integration time
Absolute brightness temperature accuracy	0.5 K
Radiometric range	0-800 K
Absolute calibration	with internal ambient & external cold load
Internal calibration	gain: with internal noise standard gain + system noise: amb. temp. target + noise standard abs. cal. of humidity profiler: sky tipping calibration
Receiver and antenna thermal stabilization	Stability better than 0.03 K over full operating temp. range
Gain nonlinearity error correction	Automatic, four point method
Brightness calculation	based on exact Planck radiation law
Integration time	>=0.4 seconds for each channel, user selectable
Sampling rate for profiles	> 1 sec, user selectable
Rain / fog mitigation system	High efficient blower system (130 Watts), hydrophobic coated microwave transparent window, 1.8 kW heater module preventing formation of dew under fog conditions
Data interface	RS-232, 115 kBaud
Data rate	10 kByte/sec., RS-232
Instrument control (external)	Host: Industrial PC, temp. range -10°C to +60°C, 4 x RS232, 2 x LAN, 2 x USB
Instrument control (internal)	Embedded PC, controls all internal calibrations, data acquisition, data file backup on 1 Gbyte flash memory, control of azimuth positioner, communication with host, can run measurements independently from host PC
Housekeeping	all system parameters, calibration history documentation
Retrieval algorithms	neural network, lin. / nonlin. regression algorithms
Optical resolution	HPBW: 3.5° for water vapour, 1.8° for temperature profiler
Sidelobe level	<-30dBc

Code:	RPG-MWR-STD-TM	Technical Manual (standard radiometers)	 RADIOMETER Physics GmbH
Date:	11.07.2011		
Issue:	01/00		
Page:	18 / 45		

Pointing speed (elevation)	45°/sec
Pointing speed (azimuth), optional	40°/sec
Operating temperature range	-40 °C to 45 °C
Power consumption	<120 Watts average, 350 Watts peak for warming-up (without dew blower heater), blower: 130 Watts max.
Lightning protection	Power line: circuit breakers Data line: Fiber optics data cable (max. length: 1400 m)
Input voltage	90-230 V AC, 50 to 60 Hz
Weight	60 kg (without dew blower)
Dimensions	63x36x90cm ³

 RADIOMETER Physics GmbH	Technical Manual (standard radiometers)	Code:	RPG-MWR-STD-TM
		Date:	11.07.2011
		Issue:	01/00
		Page:	19 / 45

RPG-LHATPRO (tropospheric ultra low humidity / temperature profiler):

Parameter	Specification
Humidity profile performance	Vertical resolution: BL-Mode: 50 m (range 0-1000 m) 100 m (range 1000-2000 m) 300 m (range 2000-5000 m), 500 m (range 5000-10000 m) Accuracy: 0.02 g/m ³ RMS (absolute hum.) 5% RMS (rel. humidity)
Temperature profile performance	Vertical resolution: BL-Mode: 50 m (range 0-1200 m) Z-Mode: 200 m (range 1200-5000 m) 400 m (range 5000-10000 m) Accuracy: 0.25 K RMS (range 0-500 m) 0.50 K RMS (range 500-1200 m) 0.75 K RMS (range 1200-4000 m) 1.00 K RMS (range 4000-10000 m)
IR radiometer option	9.2-10.6 μm band, accuracy 1 K, noise: 0.2 K RMS
LWP	Accuracy: +/- 20 g/m ² Noise: 5 g/m ² RMS
IWV	Accuracy: +/-0.02 kg/m ² RMS Noise: 0.005 kg/m ² RMS
Full sky IWV maps (only with azimuth positioner option)	350 points in 6 minutes rapid scanning
Satellite tracking mode (only with azimuth positioner option)	Determines wet/dry delay and atmospheric attenuation along line of sight for all visible GPS / Galileo satellites in a single scan (2 minutes)
Channel center frequencies	Hum-Profiler: 183.31 +/- 0.6 GHz, +/- 1.5 GHz, +/- 2.5 GHz, +/- 3.5 GHz, +/- 5.0 GHz, +/- 7.0 Hz, (+/- 12.5 GHz) V-Band: 51.26 GHz, 52.28 GHz, 53.86 GHz, 54.94 GHz, 56.66 GHz, 57.3 GHz, 58.0 GHz
Channel bandwidth	2000 MHz @ 58.0 GHz, 1000 MHz @ 57.3 GHz, 600 MHz @ 56.66 GHz, 230 MHz @ all other V-band frequencies H-Profiler: 2000 MHz @183.31 +/-12.5 GHz, 1000 MHz @183.31 +/-7.0 GHz, 250 MHz at all other channels
System noise temperatures	1500 K typ. for 183 GHz WV profiler, <700 K for temperature profiler
Radiometric resolution	0.20 K RMS @ 1.0 sec integration time
Absolute brightness temperature accuracy	0.5 K (V-Band), 1.0 K (183 GHz band)
Radiometric range	0-800 K
Absolute calibration	with internal ambient & external cold load
Internal calibration	gain: with internal noise standard gain + system noise: amb. temp. target +

Code:	RPG-MWR-STD-TM	Technical Manual (standard radiometers)	 RADIOMETER Physics GmbH
Date:	11.07.2011		
Issue:	01/00		
Page:	20 / 45		

	noise standard
Receiver and antenna thermal stabilization	Stability better than 0.03 K over full operating temp. range
Gain nonlinearity error correction	Automatic, four point method
Brightness calculation	based on exact Planck radiation law
Integration time	>=1.0 seconds for each channel, user selectable
Sampling rate for profiles	> 1 sec, user selectable
Rain / fog mitigation system	High efficient blower system (130 Watts), hydrophobic coated microwave transparent window, 1.8 kW heater module preventing formation of dew under fog conditions
Data interface	RS-232, 115 kBaud
Data rate	10 kByte/sec., RS-232
Instrument control (external)	Host: Industrial PC, temp. range -10°C to +60°C, 4 x RS232, 2 x LAN, 2 x USB
Instrument control (internal)	Embedded PC, controls all internal calibrations, data acquisition, data file backup on 1 Gbyte flash memory, control of azimuth positioner, communication with host, can run measurements independently from host PC
Housekeeping	all system parameters, calibration history documentation
Retrieval algorithms	neural network, lin. / nonlin. regression algorithms
Optical resolution	HPBW: 3.5° for water vapour, 1.8° for temperature profiler
Sidelobe level	<-30dBc
Pointing speed (elevation)	45°/sec
Pointing speed (azimuth), optional	40°/sec
Operating temperature range	-40°C to 45°C
Power consumption	<120 Watts average, 350 Watts peak for warming-up (without dew blower heater), blower: 130 Watts max.
Lightning protection	Power line: circuit breakers Data line: Fiber optics data cable (max. length: 1400 m)
Input voltage	90-230 V AC, 50 to 60 Hz
Weight	60 kg (without dew blower)
Dimensions	63x36x90cm ³

 RADIOMETER Physics GmbH	Technical Manual (standard radiometers)	Code:	RPG-MWR-STD-TM
		Date:	11.07.2011
		Issue:	01/00
		Page:	21 / 45

RPG-HUMPRO (tropospheric humidity profiler):

Parameter	Specification
Humidity profile performance	Vertical resolution: 200 m (range 0-2000 m) 400 m (range 2000-5000 m), 800 m (range 5000-10000 m) Accuracy: 0.4 g/m ³ RMS (absolute hum.) 5% RMS (rel. humidity)
IR radiometer option	9.2-10.6 μm band, accuracy 1 K, noise: 0.2 K RMS
LWP	Accuracy: +/- 20 g/m ² Noise: 2 g/m ² RMS
IWV	Accuracy: +/-0.2 kg/m ² RMS Noise: 0.05 kg/m ² RMS
Full sky IWV and LWP maps (only with azimuth positioner option)	350 points in 6 minutes rapid scanning
Satellite tracking mode (only with azimuth positioner option)	Determines wet/dry delay and atmospheric attenuation along line of sight for all visible GPS / Galileo satellites in a single scan (2 minutes)
Channel center frequencies	K-Band: 22.24 GHz, 23.04 GHz, 23.84 GHz, 25.44 GHz, 26.24 GHz, 27.84 GHz, 31.4 GHz
Channel bandwidth	230 MHz all frequencies
System noise temperatures	<400 K
Radiometric resolution	0.10 K RMS @ 1.0 sec integration time
Absolute brightness temperature accuracy	0.5 K
Radiometric range	0-800 K
Absolute calibration	with internal ambient & external cold load
Internal calibration	gain: with internal noise standard gain + system noise: amb. temp. target + noise standard abs. cal. by sky tipping calibration
Receiver and antenna thermal stabilization	Stability better than 0.03 K over full operating temp. range
Gain nonlinearity error correction	Automatic, four point method
Brightness calculation	based on exact Planck radiation law
Integration time	>=0.4 seconds for each channel, user selectable
Sampling rate for profiles	> 1 sec, user selectable
Rain / fog mitigation system	High efficient blower system (130 Watts), hydrophobic coated microwave transparent window, 1.8 kW heater module preventing formation of dew under fog conditions
Data interface	RS-232, 115 kBaud
Data rate	10 kByte/sec., RS-232
Instrument control (external)	Host: Industrial PC, temp. range -10°C to +60°C, 4 x RS232, 2 x LAN, 2 x USB

Code:	RPG-MWR-STD-TM
Date:	11.07.2011
Issue:	01/00
Page:	22 / 45

Technical Manual
(standard radiometers)



Instrument control (internal)	Embedded PC, controls all internal calibrations, data acquisition, data file backup on 1 Gbyte flash memory, control of azimuth positioner, communication with host, can run measurements independently from host PC
Housekeeping	all system parameters, calibration history documentation
Retrieval algorithms	neural network, lin. / nonlin. regression algorithms
Optical resolution	HPBW: 3.5° for water vapour, 1.8° for temperature profiler
Sidelobe level	< -30dBc
Pointing speed (elevation)	45°/sec
Pointing speed (azimuth), optional	40°/sec
Operating temperature range	-40 °C to 45 °C
Power consumption	<100 Watts average, 250 Watts peak for warming-up (without dew blower heater), blower: 130 Watts max.
Lightning protection	Power line: circuit breakers Data line: Fiber optics data cable (max. length: 1400 m)
Input voltage	90-230 V AC, 50 to 60 Hz
Weight	55 kg (without dew blower)
Dimensions	63x36x90cm ³

 RADIOMETER Physics GmbH	Technical Manual (standard radiometers)	Code:	RPG-MWR-STD-TM
		Date:	11.07.2011
		Issue:	01/00
		Page:	23 / 45

RPG-TEMPRO (tropospheric temperature profiler):

Parameter	Specification
Temperature profile performance	Vertical resolution: BL-Mode: 50 m (range 0-1200 m) Z-Mode: 200 m (range 1200-5000 m) 400 m (range 5000-10000 m) Accuracy: 0.25 K RMS (range 0-500 m) 0.50 K RMS (range 500-1200 m) 0.75 K RMS (range 1200-4000 m) 1.00 K RMS (range 4000-10000 m)
Cloud base height (only with IR radiometer option)	Accuracy: cloud base height: 50 m (range 0-300 m) 100 m (range 300-1000 m) 200 m (range 1000-3000 m) 400 m (range 3000-5000 m) 600 m (range 5000-10000 m) Threshold: 50 g/m ² LWP
IR radiometer option	9.2-10.6 μ m band, accuracy 1 K, noise: 0.2 K RMS
Channel center frequencies	51.26 GHz, 52.28 GHz, 53.86 GHz, 54.94 GHz, 56.66 GHz, 57.3 GHz, 58.0 GHz
Channel bandwidth	2000 MHz @ 58.0 GHz, 1000 MHz @ 57.3 GHz, 600 MHz @ 56.66 GHz, 230 MHz @ all other frequencies
System noise temperatures	<700 K
Radiometric resolution	: 0.20 K RMS @ 1.0 sec integration time
Absolute brightness temperature accuracy	1.0 K
Radiometric range	0-800 K
Absolute calibration	with internal ambient & external cold load
Internal calibration	gain: with internal noise standard gain + system noise: amb. temp. target + noise standard
Receiver and antenna thermal stabilization	Stability better than 0.03 K over full operating temp. range
Gain nonlinearity error correction	Automatic, four point method
Brightness calculation	based on exact Planck radiation law
Integration time	\geq 0.4 seconds for each channel, user selectable
Sampling rate for profiles	> 1 sec, user selectable
Rain / fog mitigation system	High efficient blower system (130 Watts), hydrophobic coated microwave transparent window, 1.8 kW heater module preventing formation of dew under fog conditions
Data interface	RS-232, 115 kBaud
Data rate	10 kByte/sec., RS-232
Instrument control (external)	Host: Industrial PC, temp. range -10°C to +60°C, 4 x RS232, 2 x LAN, 2 x USB
Instrument control (internal)	Embedded PC, controls all internal

Code:	RPG-MWR-STD-TM
Date:	11.07.2011
Issue:	01/00
Page:	24 / 45

Technical Manual
(standard radiometers)



	calibrations, data acquisition, data file backup on 1 Gbyte flash memory, control of azimuth positioner, communication with host, can run measurements independently from host PC
Housekeeping	all system parameters, calibration history documentation
Retrieval algorithms	neural network, lin. / nonlin. regression algorithms
Optical resolution	HPBW: 3.5° for water vapour, 1.8° for temperature profiler
Sidelobe level	<-30dBc
Pointing speed (elevation)	45°/sec
Pointing speed (azimuth), optional	40°/sec
Operating temperature range	-40°C to 45°C
Power consumption	<100 Watts average, 250 Watts peak for warming-up (without dew blower heater), blower: 130 Watts max.
Lightning protection	Power line: circuit breakers Data line: Fiber optics data cable (max. length: 1400 m)
Input voltage	90-230 V AC, 50 to 60 Hz
Weight	55 kg (without dew blower)
Dimensions	63x36x90cm ³

 RADIOMETER Physics GmbH	Technical Manual (standard radiometers)	Code:	RPG-MWR-STD-TM
		Date:	11.07.2011
		Issue:	01/00
		Page:	25 / 45

RPG-LWP / RPG-LWP-U90 (LWP / IWV / Wet Delay):

Parameter	Specification
IR radiometer option	9.2-10.6 μm band, accuracy 1 K, noise: 0.2 K RMS
LWP	Accuracy: +/- 20 g/m^2 (RPG-LWP), +/- 10 g/m^2 (RPG-LWP-U90), Noise: 2 g/m^2 RMS
IWV	Accuracy: +/-0.3 kg/m^2 RMS Noise: 0.05 kg/m^2 RMS
Full sky IWV and LWP maps (only with azimuth positioner option)	350 points in 6 minutes rapid scanning
Satellite tracking mode (only with azimuth positioner option)	Determines wet/dry delay and atmospheric attenuation along line of sight for all visible GPS / Galileo satellites in a single scan (2 minutes)
Channel center frequencies	K-Band: 23.84 GHz, 31.4 GHz, 90.0 GHz (RPG-LWP-U90 only)
Channel bandwidth	2000 MHz @ 90.0 GHz, 230 MHz @ all other frequencies
System noise temperatures	<400 K for K-band, < 700 K for 90 GHz channel (RPG-LWP-U90 only)
Radiometric resolution	K-Band: 0.10 K RMS, 90 GHz: 0.20 K RMS @ 1.0 sec integration time
Absolute brightness temperature accuracy	0.5 K in K-band, 1.0 K at 90 GHz
Radiometric range	0-800 K
Absolute calibration	with internal ambient & external cold load
Internal calibration	gain: with internal noise standard gain + system noise: amb. temp. target + noise standard abs. cal. by sky tipping calibration
Receiver and antenna thermal stabilization	Stability better than 0.03 K over full operating temp. range
Gain nonlinearity error correction	Automatic, four point method
Brightness calculation	based on exact Planck radiation law
Integration time	≥ 0.4 seconds for each channel, user selectable
Sampling rate	> 1 sec, user selectable
Rain / fog mitigation system	High efficient blower system (130 Watts), hydrophobic coated microwave transparent window, 1.8 kW heater module preventing formation of dew under fog conditions
Data interface	RS-232, 115 kBaud
Data rate	10 kByte/sec., RS-232
Instrument control (external)	Host: Industrial PC, temp. range -10°C to +60°C, 4 x RS232, 2 x LAN, 2 x USB
Instrument control (internal)	Embedded PC, controls all internal calibrations, data acquisition, data file backup on 1 Gbyte flash memory, control of azimuth

Code:	RPG-MWR-STD-TM
Date:	11.07.2011
Issue:	01/00
Page:	26 / 45

Technical Manual
(standard radiometers)



	positioner, communication with host, can run measurements independently from host PC
Housekeeping	all system parameters, calibration history documentation
Retrieval algorithms	neural network, lin. / nonlin. regression algorithms
Optical resolution	HPBW: 3.5° for K-band, 2.0° @ 90 GHz
Sidelobe level	<-30dBc
Pointing speed (elevation)	45°/sec
Pointing speed (azimuth), optional	40°/sec
Operating temperature range	-40°C to 45°C
Power consumption	<120 Watts average, 300 Watts peak for warming-up (without dew blower heater), blower: 130 Watts max.
Lightning protection	Power line: circuit breakers Data line: Fiber optics data cable (max. length: 1400 m)
Input voltage	90-230 V AC, 50 to 60 Hz
Weight	58 kg (without dew blower)
Dimensions	63x36x90cm ³

 RADIOMETER Physics PG GmbH	Technical Manual (standard radiometers)	Code:	RPG-MWR-STD-TM
		Date:	11.07.2011
		Issue:	01/00
		Page:	27 / 45

RPG-150-90 / RPG-DP150-90 (precision LWP radiometer):

Parameter	Specification
IR radiometer option	9.2-10.6 μm band, accuracy 1 K, noise: 0.2 K RMS
LWP	Accuracy: $\pm 5 \text{ g/m}^2$ Noise: 1 g/m^2 RMS Detection of ultra low LWP
LWP maps (only with azimuth positioner option)	350 points in 6 minutes rapid scanning
Channel center frequencies	K-Band: 90.0 GHz, 150.0 GHz
Channel bandwidth	2000 MHz
System noise temperatures	$< 900 \text{ K @ } 90 \text{ GHz channel, } < 1300 \text{ K @ } 150.0 \text{ GHz}$, including full Dicke switch calibration standards
Radiometric resolution	0.20 K RMS @ 1.0 sec integration time
Absolute brightness temperature accuracy	1.0 K
Radiometric range	0-800 K
Absolute calibration	with internal ambient & external cold load
Internal calibration	gain + system noise: Dicke Switch + noise standard abs. cal. by sky tipping calibration
Receiver and antenna thermal stabilization	Stability better than 0.03 K over full operating temp. range
Gain nonlinearity error correction	Automatic, four point method
Brightness calculation	based on exact Planck radiation law
Integration time	≥ 1.0 second for each channel, user selectable
Rain / fog mitigation system	High efficient blower system (130 Watts), hydrophobic coated microwave transparent window, 1.8 kW heater module preventing formation of dew under fog conditions
Data interface	RS-232, 115 kBaud
Data rate	10 kByte/sec., RS-232
Instrument control (external)	Host: Industrial PC, temp. range -10°C to $+60^\circ\text{C}$, 4 x RS232, 2 x LAN, 2 x USB
Instrument control (internal)	Embedded PC, controls all internal calibrations, data acquisition, data file backup on 1 Gbyte flash memory, control of azimuth positioner, communication with host, can run measurements independently from host PC
Housekeeping	all system parameters, calibration history documentation
Retrieval algorithms	lin. / nonlin. regression algorithms
Optical resolution	HPBW: 2.0°
Sidelobe level	$< -30\text{dBc}$
Pointing speed (elevation)	$45^\circ/\text{sec}$
Pointing speed (azimuth), optional	$40^\circ/\text{sec}$
Operating temperature range	-40°C to 45°C

Code:	RPG-MWR-STD-TM	Technical Manual (standard radiometers)	 RADIOMETER Physics GmbH
Date:	11.07.2011		
Issue:	01/00		
Page:	28 / 45		

Power consumption	<120 Watts average, 300 Watts peak for warming-up (without dew blower heater), blower: 130 Watts max.
Lightning protection	Power line: circuit breakers Data line: Fiber optics data cable (max. length: 1400 m)
Input voltage	90-230 V AC, 50 to 60 Hz
Weight	58 kg (without dew blower)
Dimensions	63x36x90cm ³

3 Advantages of Filterbank Systems over Sequentially Scanning Radiometers

3.1 Introduction

Passive microwave radiometers are well suited to measure humidity and temperature profiles in the troposphere of the earth, as well as integrated quantities like the integrated water vapour (IWV) and liquid water content of clouds (LWP). The humidity information is taken from the shape of the single water vapour line at 22.24 GHz (line width approx. +/-6 GHz) while the temperature profile is derived from the shape of the oxygen line around 60 GHz (line width approx. +/- 8 GHz. Because the lines are symmetrical, only one half of the line has to be measured for profiling. The lines are strongly pressure broadened (see Fig.3.1).

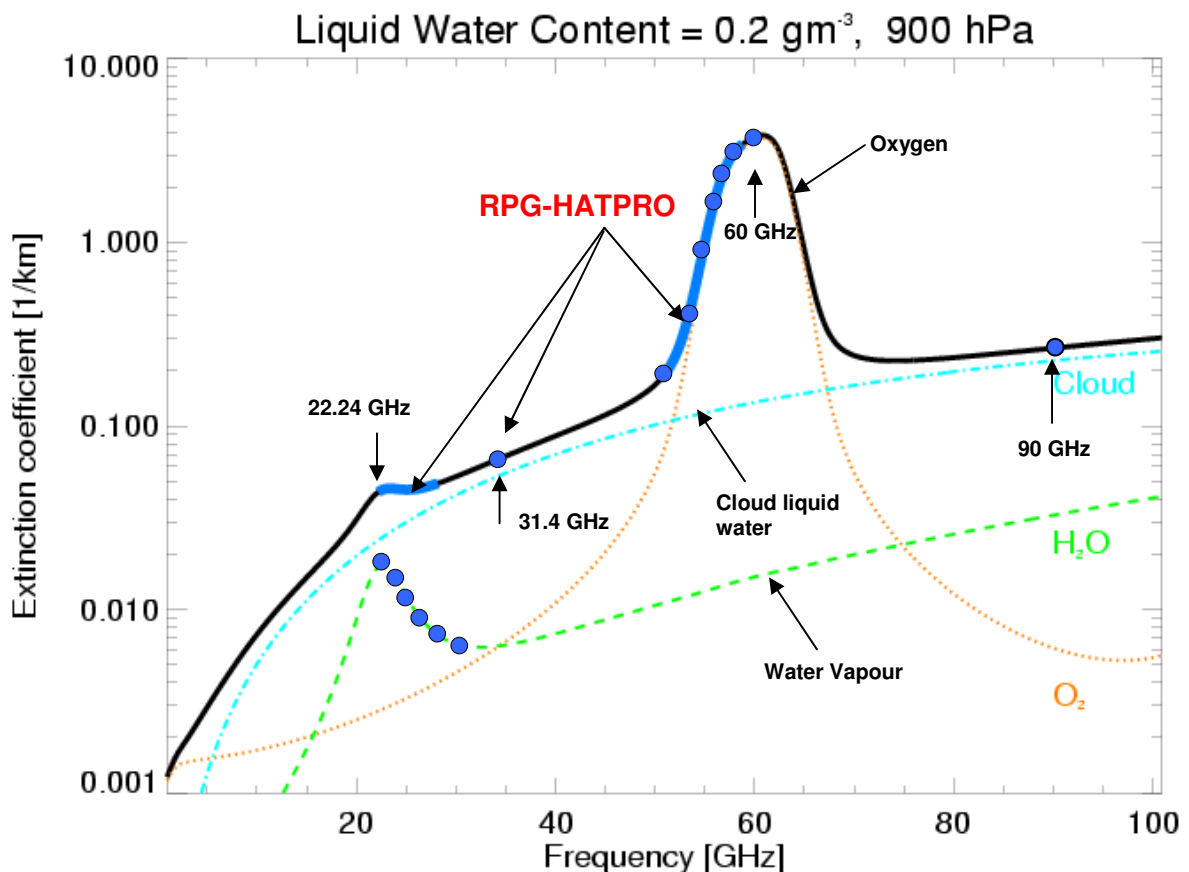

Fig.3.1: Spectral features used for microwave atmospheric profiling

Because of the pressure broadened line shapes, the information content of the water vapour line and oxygen line are limited to 3 (water vapour) and 4 (oxygen line) independent degrees of freedom. This means that 3 numbers can usually completely characterize the shape of the water vapour line and 4 numbers can completely describe all the information in the oxygen line. This is similar to the fact that a point in space is uniquely defined by three numbers (three dimensions). Or in other words: A high spectral resolution is not required to measure a broad spectral line.

Consequently, in principle the measurement of four channels (at the right frequency points) is sufficient to capture the full information content in the water vapour line and 5 channels are sufficient for the oxygen line. A few more channels help to reduce noise (when measured simultaneously) and increase redundancy in the case of external interferences.

3.2 Tunable single channel vs. multiple parallel channels

The aim of the radiometer is to measure the information content in the atmospheric lines as accurate as possible which means with the lowest possible measurement noise. In order to do this, the radiometer has to measure at multiple frequencies to capture the line shapes with a maximum integration time. Two concepts have been realized: The spectrum analyzer (MP-3000, Radiometrics) concept and the direct detection filter bank (RPG-HATPRO, RPG) receiver.

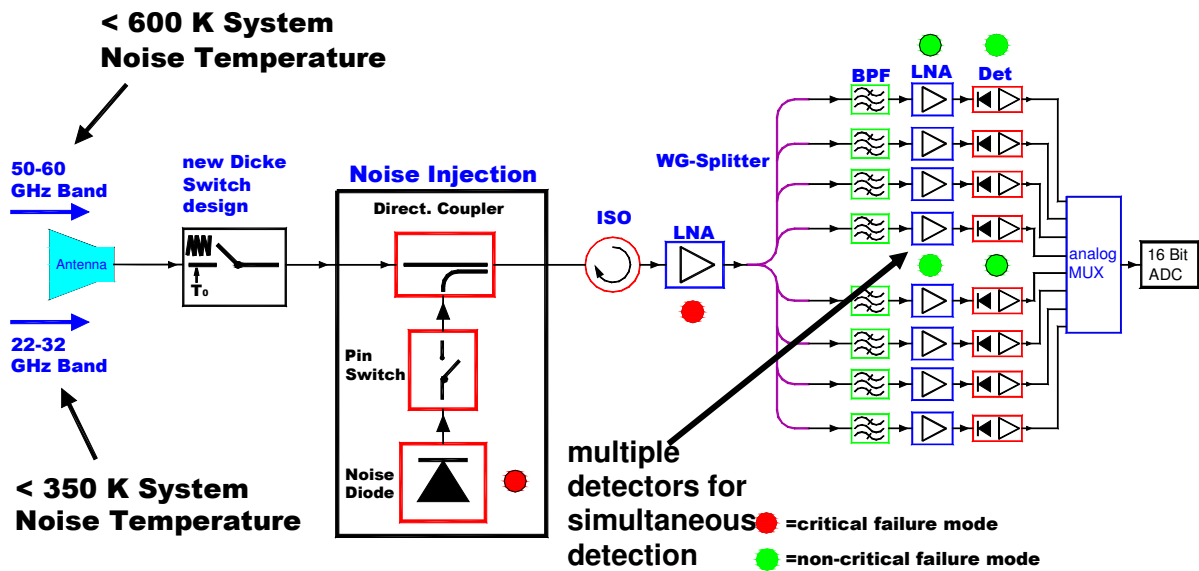

Fig.3.2: Direct detection filterbank receiver layout with failure modes.

Filter Bank:

A filter bank radiometer has multiple detection channels. This is a higher effort in the manufacturing of the receivers but it has the advantage that all the channels are detected simultaneously (in parallel) and each channel has its own filter. Each channel uses the full integration time (100% duty cycle, Fig.3.2).

The number of parallel detection channels is determined by the task of the filter bank. In the case of a temperature and humidity profiler, the number of channels should be ≥ 5 . The RPG-HATPRO uses 7 channels for each profiler in order to have some redundancy in the case of an external interference signal on one of the channels.

Spectrum Analyzer:

A spectrum analyzer uses basically a single amplifier, filter and detector chain. The receiver input can be tuned to different signal frequencies (by a synthesizer) but the detection of the signals is performed by only one detector (Fig.3.3).

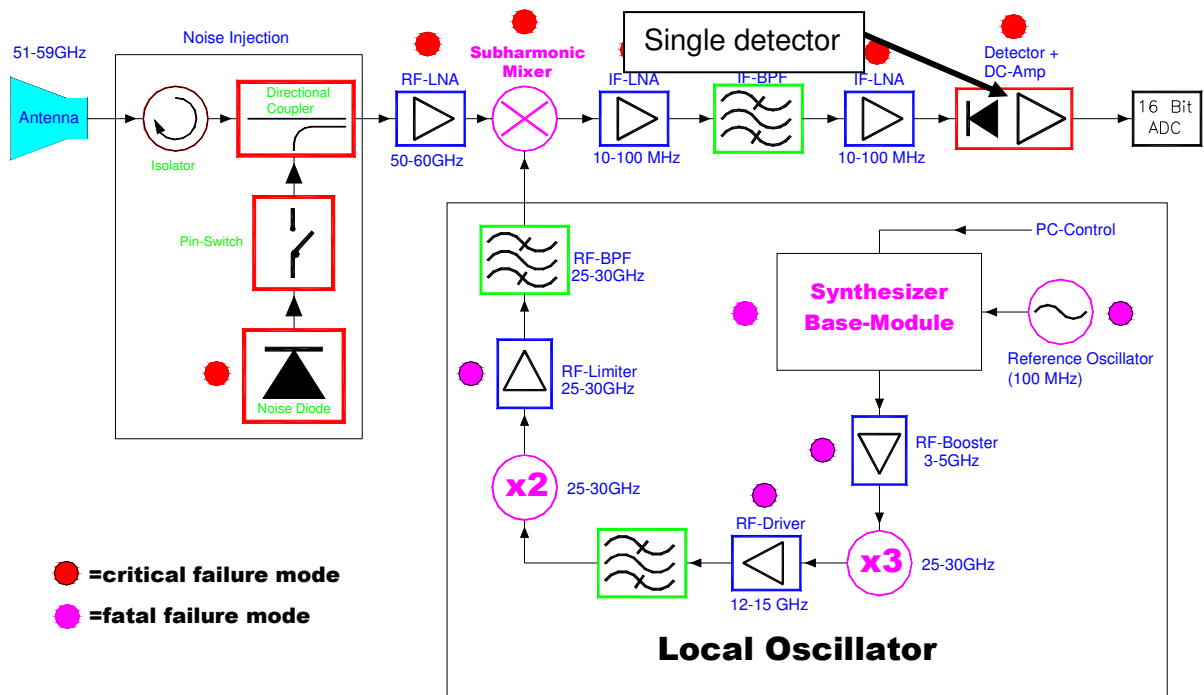

Fig.3.3: Single channel spectrum analyzer with sequential frequency scanning.

A spectrum analyzer is usually used when a high spectral resolution is required. The synthesizer can step in small steps (e.g. 10 MHz) so that it can scan the water vapour line and oxygen line with thousands of different frequency points. The important thing here is that the possible number of frequency points is high but the detection is only done by a single detector channel. During the scan, the synthesizer steps from one frequency point to the next (sequentially) and the measurement time at a single frequency point is small (duty cycle = 100% divided by the number of frequency points). A high number of frequency points is NOT required to measure the water vapour and oxygen line shapes, so the synthesizer's ability to measure at many frequency points is not an advantage. This fact is explained in more detail in the following paragraph.

3.3 How many channels are required to achieve the highest profiling accuracy?

The 22.4 GHz line is a single pressure broadened line of a H₂O rotational transition. Theoretically, if the water vapour is kept under constant pressure and temperature, the line shape is a simple Lorentzian as shown in Fig.3.4. This function is uniquely determined by two numbers, its amplitude and half-width. Therefore, only two independent pieces of information are stored in the line shape (two degrees of freedom or Eigenvalues) and only two frequency channels with minimum correlation are required to measure all information content. In the earth's troposphere, the water vapour is not at constant pressure and temperature because it

is distributed over a vertical profile and we expect the line shape to be more complicated than in Fig.3.4 with higher information content. How many degrees of freedom do we get for the real tropospheric water vapour line?

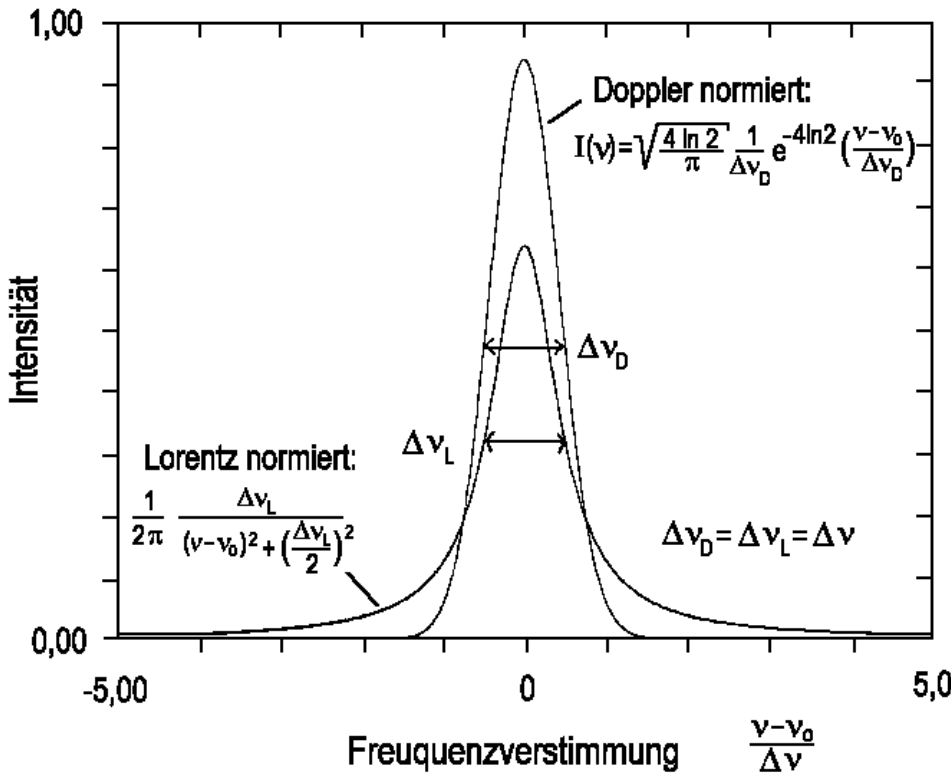

Fig.3.4: Single pressure broadened line with two independent pieces of information (amplitude and linewidth)

Prof. S. Crewell and U. Löhnert from the University of Cologne have performed an extensive analysis to answer this question. The idea is to take a set of radio soundings of e.g. one year, calculate the expected microwave spectrum for each of these atmospheric states and determine the correlation of channel pairs or groups of channels. The result of such an analysis is shown in Fig.3.5 for a one year data set taken from the Meteo Swiss sounding station in Payerne / Switzerland.

As can be seen from Fig.3.5 a) the 23.8 GHz channel is highly correlated with all other frequencies on the water vapour line (WVL) while it is less related to the window channels between 30 and 50 GHz. The 31.4 GHz channel as a window channel shows the opposite correlation to the same spectrum. This is why this channel pair has been selected as the baseline for many simple water vapour radiometers. In Fig.3.5 b) the combination of the channel pair 23.8 / 31.4 GHz reveals a correlation close to 1.0 to all frequency channels between 15 GHz and 50 GHz, except for the 22 GHz WVL centre. By adding another channel at 22.4 GHz, the correlation becomes perfect. Therefore, for this data set, the measurement of 22.4 / 23.8 and 31.4 GHz channels is fully sufficient to capture ALL information contained in the water vapour line (maximum number of 3 degrees of freedom).

Fig.3.6 illustrates a more detailed analysis of two data sets (one year each) from Payerne and Darwin (Australia) with respect to humidity and temperature profiles. The maximum

number of independent information for temperature profiling is 3 for zenith observations and 4-5 for BL scanning where the additional information is not gained by more channels but by a variation of channel weighing functions. In the case of humidity profiles, 3-4 degrees of freedom result for the Darwin data set while only 2-3 pieces of information result from the Payerne data. This is explained by the much higher humidity concentrations found at the tropical North Australian site.

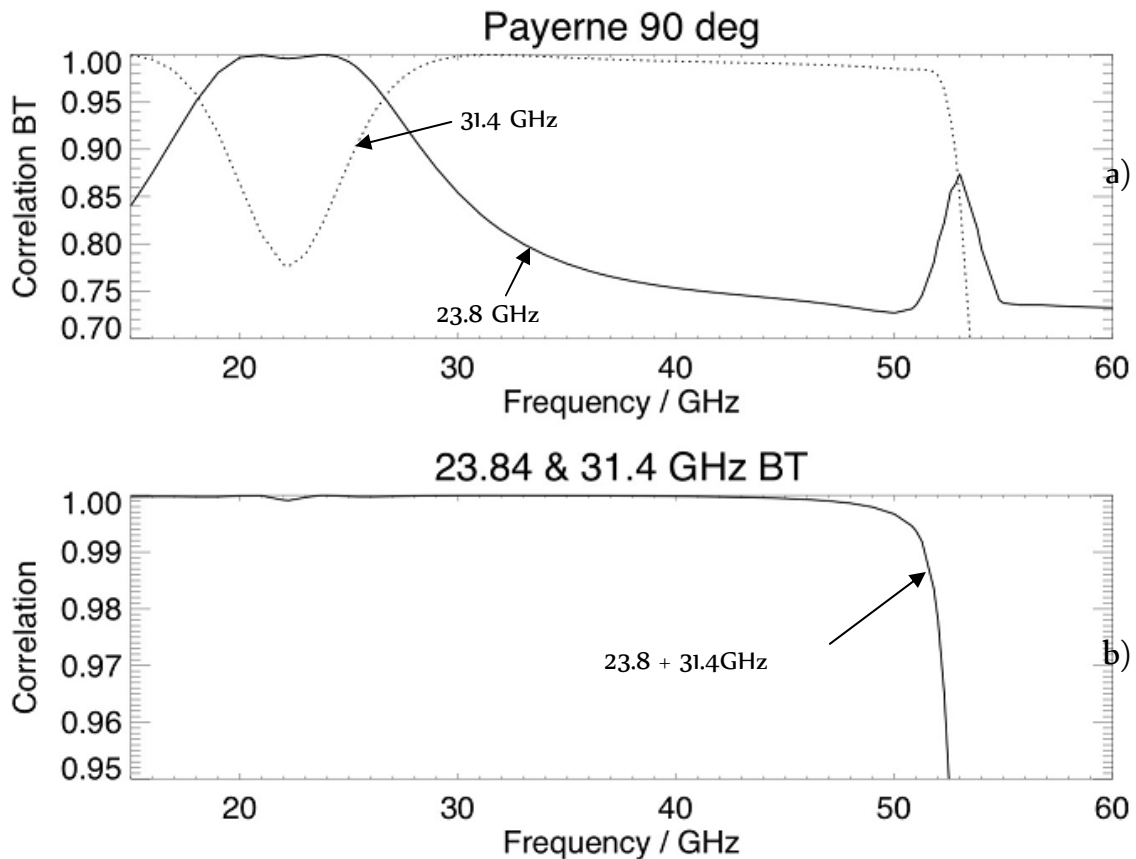

Fig.3.5: a): Correlation between the 23.8 / 31.4 GHz BT with the spectrum between 15 GHz and 60 GHz, b): Correlation between frequency pair 23.8 / 31.4 GHz and 15-60 GHz spectrum.

In other words, if the correlation between two brightness temperatures T_1 and T_2 , measured at two different frequency channels F_1 and F_2 (integration time t on each channel), is close to 1.0, the measurement at F_1 and F_2 is equivalent (contains the same information) as a measurement only at F_1 (or F_2) over an integration time $2 \cdot t$. Then we do not need both frequency channels but only F_1 or F_2 instead.

As a summary, it has been clearly shown that 4 frequency channels on each atmospheric line, when properly selected with minimum correlation, are sufficient to measure all information contained in the line shapes.

However, RPG has built a filter bank radiometer like the RPG-HATPRO, with additional varactor tuning capability of the filter bank centre frequencies. This way, by tuning a set of varactor diodes associated with the 7 channels of each filter bank, all channels can be shifted in frequency by the same frequency step or ΔF . So the 7 channels filter bank can

be extended to a 14, 21, 28, 35, ... channels filter bank. In order to check the results of Fig.5 and Fig.6 by real measurements, we developed retrieval algorithms for 7, 14, 21 and 28 channels on each atmospheric line and compared the retrieval output RMS and bias in a comparison with radio soundings.

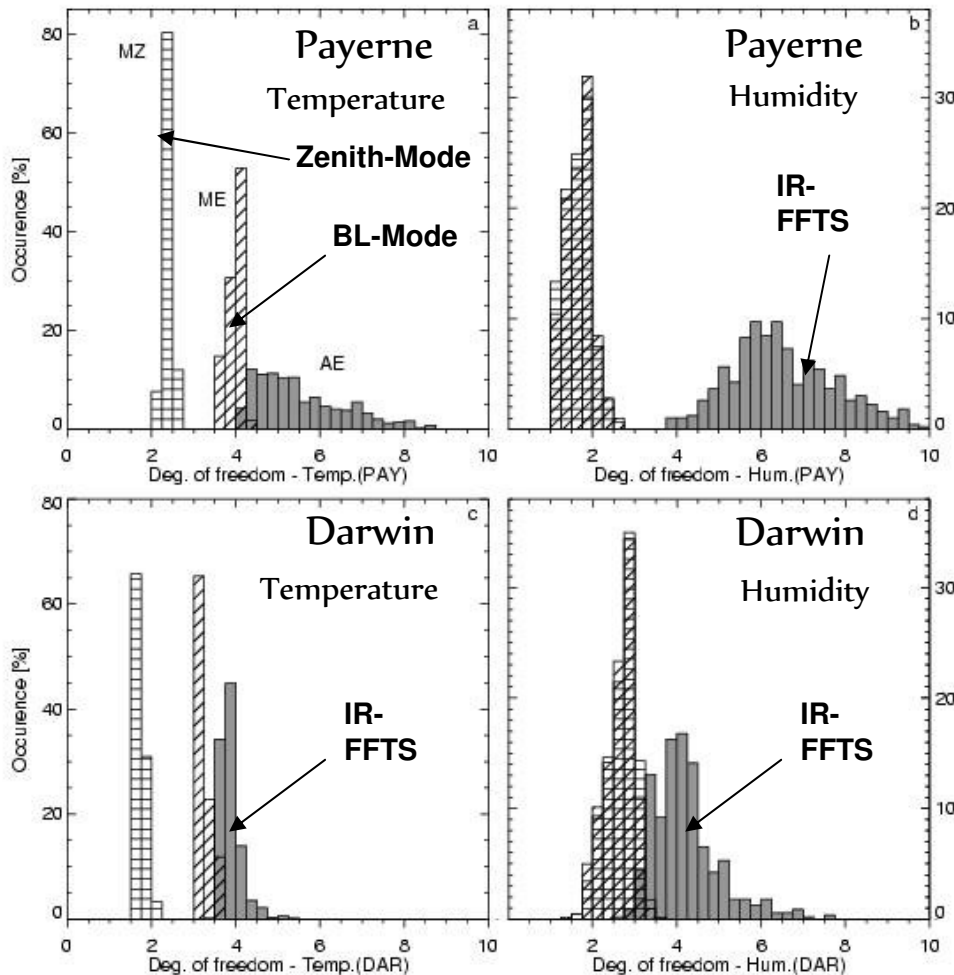

Fig.3.6: Comparison of degrees of freedom for different scanning modes (Boundary Layer scanning BL-Mode and Zenith Observation Mode) and data from an infrared FFTS spectrometer (to be ignored in this context).

The results are shown in Fig.3.7. In the case of temperature profiling, the 7 channel radiometer / retrieval works best in comparison with the radio soundings (bias errors) while the RMS is practically the same for all different channel sets. The humidity profiling retrieval performance is basically identical for the four different channel sets.

Therefore, we have proven by theory and experiment that increasing the number of microwave channels beyond 5-7 channels per line does NOT improve the profiling accuracy.

This fact is well known for more than a decade as can be seen from Fig.8 showing a frequency table published in 2001 (J.Güldner and D.Spänkuch, 'Remote Sensing of the Thermodynamic State of the Atmospheric Boundary Layer by Ground-Based Microwave Radiometry', Journal of Atmospheric and Oceanic Technology, page 925, volume 18) for a Radiometrics TP/WVP-3001 profiler. Even though this instrument is capable of tuning its

synthesizer to a few thousand different frequency points, Radiometrics provided only retrievals for 5 channels on the WVl and 7 channels on the O2-Line, because these channels contain all information stored in those spectral lines. Increasing the number of channels does NOT lead to any benefit in resolution or accuracy.

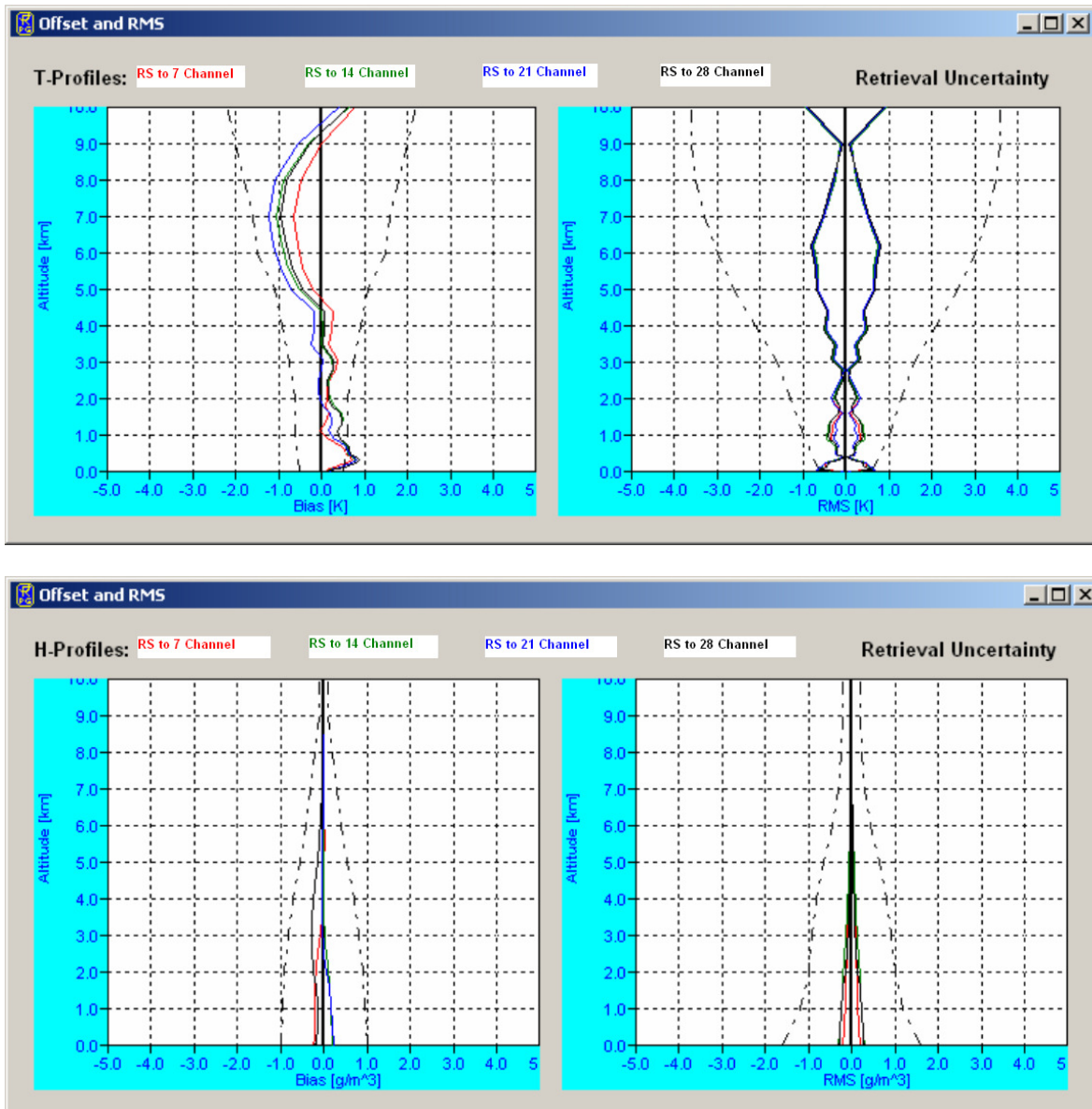

Fig.3.7: Comparison of temperature (top) and humidity (bottom) profile accuracy for 4 different radiometers operating on 7, 14, 21 and 28 different channels per line.

TABLE 1. Specification of the TP/WVP 3001 microwave profiler.

Frequency (GHz)	Beamwidth* (°)	Dominant influencing parameters
22.235	5.5	Water vapor Cloud liquid water
23.035		
23.835		
26.235		
30.000	4.5	Temperature Cloud liquid water
51.250		
52.280		
53.850		
54.940	2.7	Temperature Cloud liquid water
56.660		
57.290		
58.800		
58.800	2.3	

* Defined as full-width half-power (3 dB) beamwidth.



FIG. 1. The microwave profiler TP/WVP-3001.

Fig.3.8: Frequency table used by a spectrum analyzer system (TP/WVP-3001) in 1999.

3.4 Why is a high channel duty cycle important?

One task of a profiler is to capture all information stored in the atmospheric line shapes. We have already explained that a relatively small number of channels are sufficient to do this (see also the frequency tables of satellite radiometers for earth atmospheric observations). The other task of the radiometer is to measure this information with a high **precision** which is equivalent to the requirement of low noise. In reality, all measurements of real instruments produce noise which limits the accuracy of the measurement. Most of the noise is usually not frequency dependent (white noise) and a common technique to reduce this noise is to maximize the integration time. The higher the integration time for a measurement, the lower the noise and the higher is the precision. The noise amplitude (a measure for the amount of noise) is reduced by the square root of the integration time. Thus, increasing the integration time by a factor of 4 reduces the noise by a factor of 2. If a radiometer channel has a duty cycle of 10%, its precision is about three times less (square root of 10) compared to a radiometer channel with 100% duty cycle.

3.5 Why is a high precision important for a profiling radiometer?

1. Boundary layer temp. inversions: An important application of the profiling radiometer is the detection of low level temperature inversions. Such inversions play an important role for the thermal energy flux (they block the transport of heat and air from the ground to higher atmospheric levels) and the reduced transportation of aerosols and chemicals from the ground up into the atmosphere.

One can increase the number of independent information (the number of degrees of freedom) in a measurement of an oxygen line channel, by scanning the elevation angle. This is not an increase of information in frequency space (this would not To resolve the vertical structure of an inversion in the atmospheric boundary layer (ABL), a vertical resolution of 50 m can be achieved with this method. By only observing in zenith direction, the vertical resolution is much worse (only 250 m in the ABL).

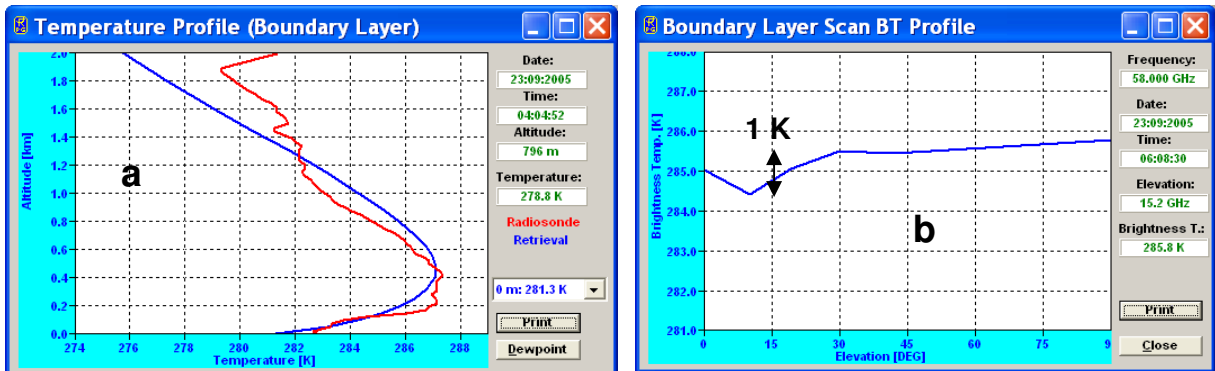

Fig.3.9: Low level temperature inversion (a) and associated brightness temperature elevation scan (b). The T_B variation in (b) is only 1 K @58 GHz for the full elevation scan (5° to 90°).

Fig.3.9 shows a typical temperature inversion and its associated brightness temperature measurement of the radiometer. A radiometer directly measures the sky brightness temperatures at different frequencies and a mathematical algorithm (called a retrieval) is used to derive the temperature profile from the sky brightness temperatures. The major task of the radiometer is to measure the sky brightness temperatures with the highest possible precision.

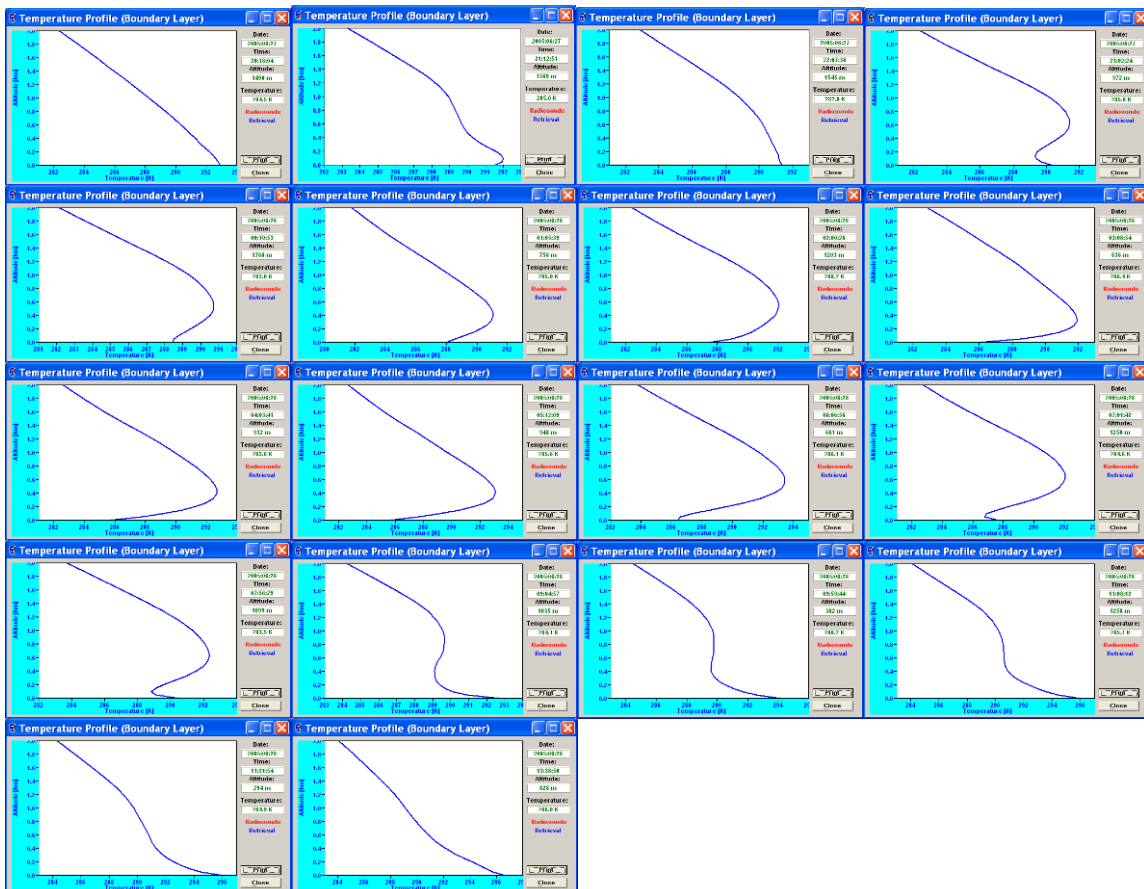

Fig.3.10: Development and decay of temperature inversions.

Code:	RPG-MWR-STD-TM	Technical Manual (standard radiometers)	 RADIOMETER Physics GmbH
Date:	11.07.2011		
Issue:	01/00		
Page:	38 / 45		

In Fig.3.9(b) the brightness temperature variation of an elevation scan is shown. All the information about the temperature inversion is stored in this scan. As can be seen from plot Fig.3.9(b), the variation is only one Kelvin. If the noise of the measurement would be higher than 0.1K, the detailed structure of the resulting temperature inversion would be hidden. Therefore a maximum integration time for each frequency point is required and 100% is the maximum one can achieve, but only with a simultaneous measurement of all frequencies. Fig.3.10 shows the formation and decay of an inversion.

One scan takes about 2 minutes with a filter bank radiometer (100% duty cycle for each channel) but would take more than 30 minutes with the MP-3000 synthesizer radiometer (duty cycle 8% for each frequency point), assuming the same precision. The temperature profile sampling period should be in the order of 10-15 minutes to monitor the inversion with sufficient time resolution.

2: Fast 2D sky mapping: Fig.3.11 shows a full sky scan of an inhomogeneous humidity field with 320 measurement points, using all 14 filter bank channels for each point. The scan duration is only 7 minutes for a filter bank radiometer.

3: Fast LWP time series: Fig.3.12 shows the rapid changes of a cloud liquid water measurement. At high wind speeds the thickness of the cloud layer above the radiometer can change within seconds. The one second temporal resolution of the filter bank radiometer is capable of monitoring these fast changes. The effective temporal resolution of the MP-3000 spectrum analyzer is only 12 seconds.

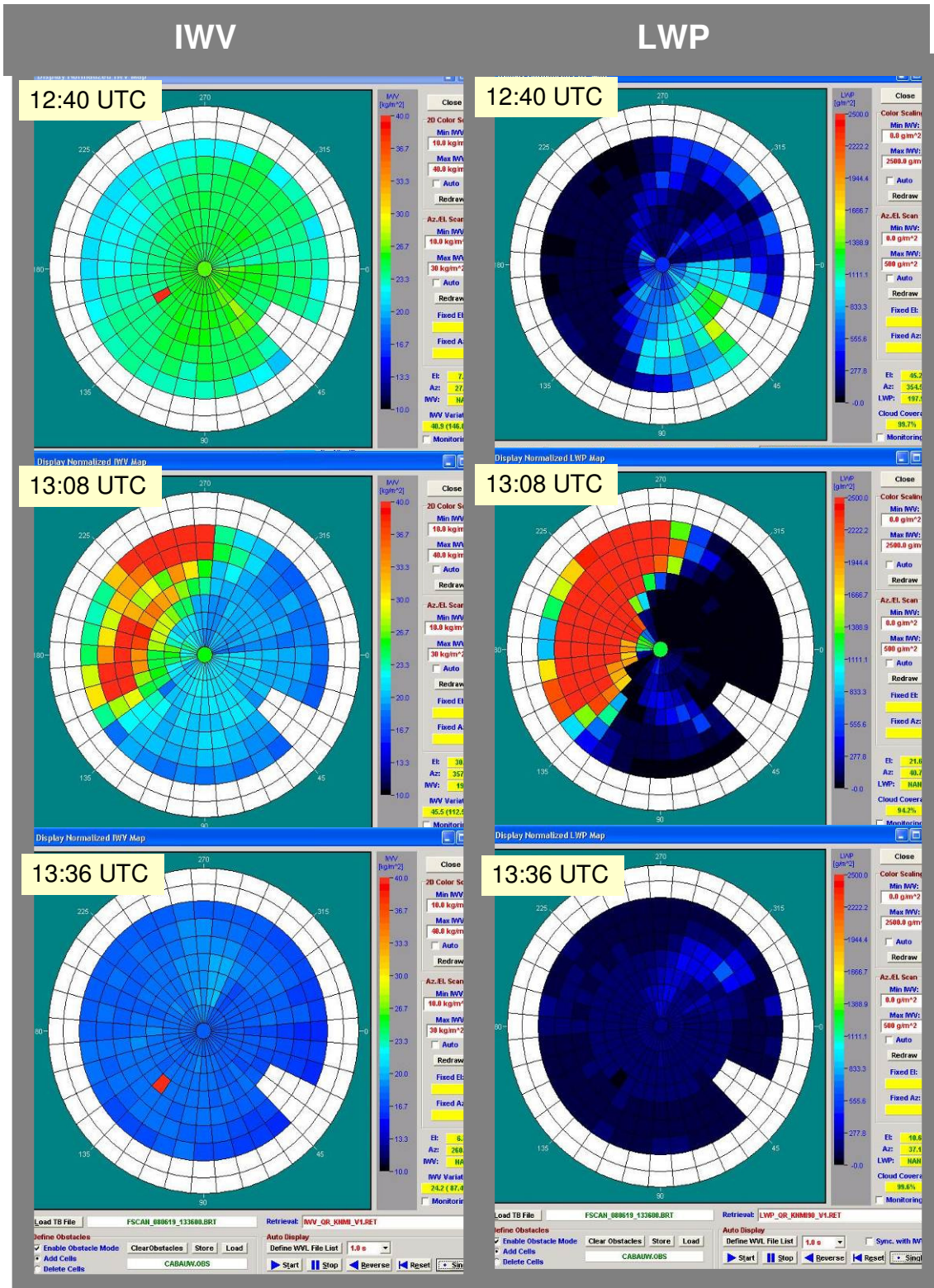

Fig.3.11: Sky volume scans of IWV and LWP with 340 points, showing an inhomogeneous humidity field (frontal passage)

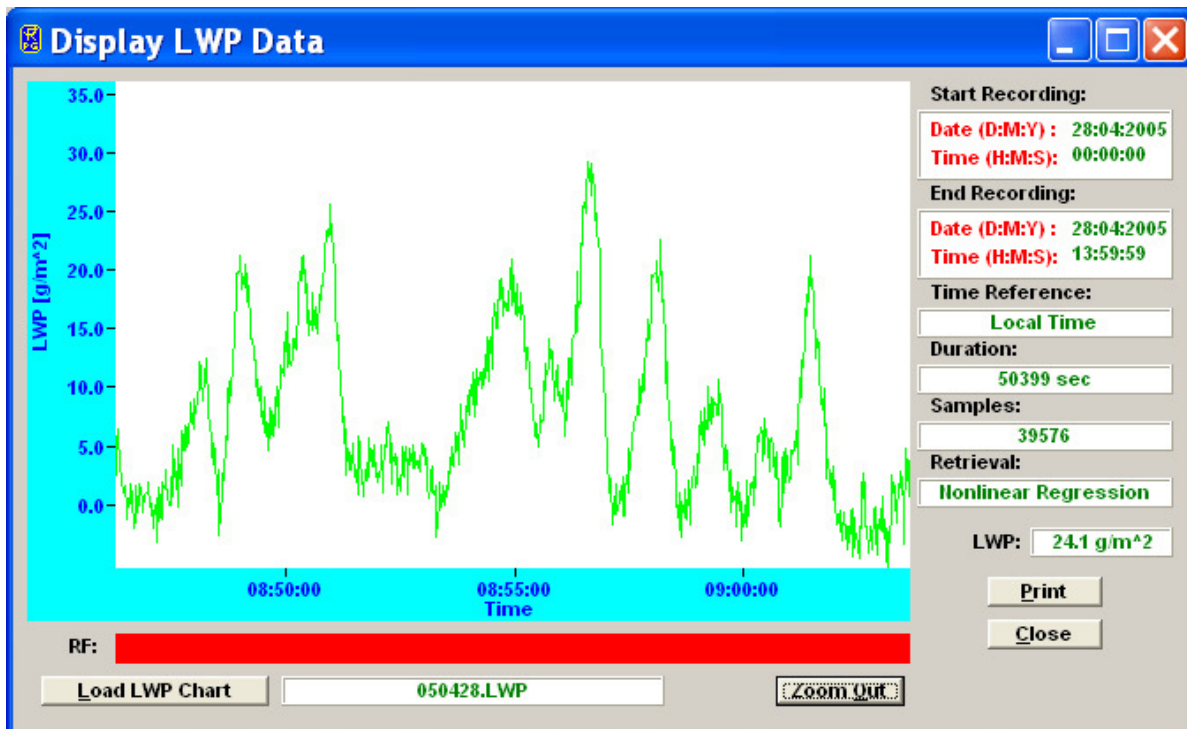

Fig.3.12: High temporal sampling required for LWP measurements (e.g. cloud modelling).

3.6 Any other important radiometer features?

- 1. High spatial resolution:** The optical beam width of the radiometer should be as small as possible. During the ABL scans for temperature profiling, the radiometer scans down to 5° elevation. If the radiometer beam width is too high (e.g. +/- 4°), the beam is affected by the ground emission and the measurement is spoiled. Also a wide beam tends to average the contributions from different layers in the ABL and therefore reduces the vertical resolution. Unfortunately, a narrow beam requires a bigger antenna. This is why the RPG-HATPRO antenna size (250 mm) is almost twice as big as the MP-3000 antenna size (150 mm) and the instrument is heavier because of that. Since the RPG-HATPRO is still a portable radiometer, this disadvantage is accepted by most users.
- 2. Low sensitivity to external interferences:** The RPG-HATPRO is a direct detection radiometer. It does not have any mixers or active sources (local oscillators) which down-convert the reception frequency band (e.g. 22-32 GHz) to a low frequency band (e.g. 100 MHz, as for the MP-3000). Therefore the RPG-HATPRO is totally immune to interferences in these low frequency bands (also called IF band = Intermediate Frequency band). Unfortunately, many external sources around 100 MHz exist, like strong radio transmitters (FM radio is operated between 82 MHz and 104 MHz), mobile phone stations, etc.

Direct detection receivers with their advantages require a signal filtering and detection at the high reception frequencies. State of the art technology developed over the last 7-10 years has made this receiver technology feasible.

3.7 Summary

Major performance differences between synthesizer designs (as the Radiometrics MP-3000A) and the RPG-HATPRO dual profilers:

Topic	MP-3000A	RPG-HATPRO
Sampling Rate	10 seconds	1 second
Antenna beam resolution	6° (Hum. Profiler), 2.5° (Temp. Profiler)	3.5° (Hum. Profiler), 1.8° (Temp. Profiler)
Full Sky Mapping Capability	No	Yes (5 min. duration)
Boundary Layer Temperature resolution	200 m	50 m
Boundary Layer Temperature accuracy	0.5 K RMS	0.25 K RMS
Liquid water profiling technique (*)	neural network	PARCWAPT expert system
Seasonal retrieval support	No	Yes
Time for absolute calibration	30-60 minutes	2 minutes
Absolute calibration interval	6 month and after transportation	6 month
Dicke switch calibration standard	No	Yes
Long term TB drift	0.5 K / year	0.2 K / year
Receiver Technology	FAA	DDFA
Channels	4000, serial scanning	14, fixed, parallel scanning
Channels for profiling	5 (Hum. Prof), 7(Temp. Prof)	7 (Hum. Prof), 7(Temp. Prof)
Time resolution	12 seconds	1 second
Radiometric Noise [10 sec. integration time]	0.2 K RMS	0.06 K RMS
Thermal receiver stability	0.5 K	0.03 K
Dew Blower Heater system (prevents formation of liquid water on microwave window under fog conditions)	No	Yes
Elevation scanning for IR radiometer	No	Yes
Maximum number of IR channels	1	2
Channel centre frequency accuracy	10 MHz	0.5 MHz
Internal file backup system (1 GByte capacity flash)	No	Yes
Measurement without external PC possible (Auto-	No	Yes

Run)		
Level 0 data availability (raw data)	No	Yes
Frequency extension possible (Master / Slave radiometers)	No	Yes
Data cable, max. length	copper, 30 m	fiber optics, 1400 m
Serial data speed	9.600 Baud	115.000 Baud
Spurious signal emission (not purely passive instrument)	Yes	No
Immunity to IF interference (Radio Transmitters, TV, cell phones, etc.)	No	Yes
Software features:		
- data quality control system	No	Yes
- automatic RF interference removal	Yes	Yes
- data levels 0,1,2 available	only levels 1,2	all levels
- detailed instrument status control	No	Yes
- housekeeping data	Yes	Yes
- calibration data archiving	Yes	Yes
- automatic data archiving / concatenation	No	Yes
- data formats	only Binary, ASCII	Binary, ASCII, netCDF, BUFR
- current sample file generation (new data files every minute or longer)	No	Yes
- Skew-T diagram	No	Yes
- Tephigram	No	Yes
- Emagram	No	Yes
- Stüve diagram	No	Yes
- auto- north adjustment of azimuth	No	Yes
- full retrieval support	Yes	Yes
- customer retrieval implementation	Yes	Yes
- satellite tracking of GPS, Galileo	Yes, only GPS	Yes
- full sky scanning mode with sun suppr.	No	Yes
- 24 hour history display	Yes	Yes

- graphics displays of all data types	Yes	Yes
- multiple measurement batches	No	Yes
- arbitrary scanning patterns	No	Yes
- autom. recovery after power failures	No	Yes
- AutoViewer	No	Yes
- Master / Slave mode for radiometer extension by another radiometer	No	Yes
- web server application for remote contr.	Yes	Yes

4 Electrical Connections

The radiometer power cable is split into AC1 (supply for radiometer, blue) and AC2 (supply for blower heater module, yellow). AC1 can be buffered via a UPS system (see Fig.4.1) in the range 100-240 V/AC, 50-60 Hz. AC2 must be connected directly to a power outlet at 220 V/AC or via a 110-to-220 V transformer to a 110 V/AC power outlet. The heater will not be damaged if it is connected to a 110 V/AC line, but the heater power is reduced from its standard 1800 Watts down to 450 Watts in this case. 450 Watts of heater power is not efficient enough for drying the microwave window. For 110 V/AC outlets, it is therefore recommended to use a transformer to produce 220 V/AC to power the heater.

Fig.4.1: Summary of Connections

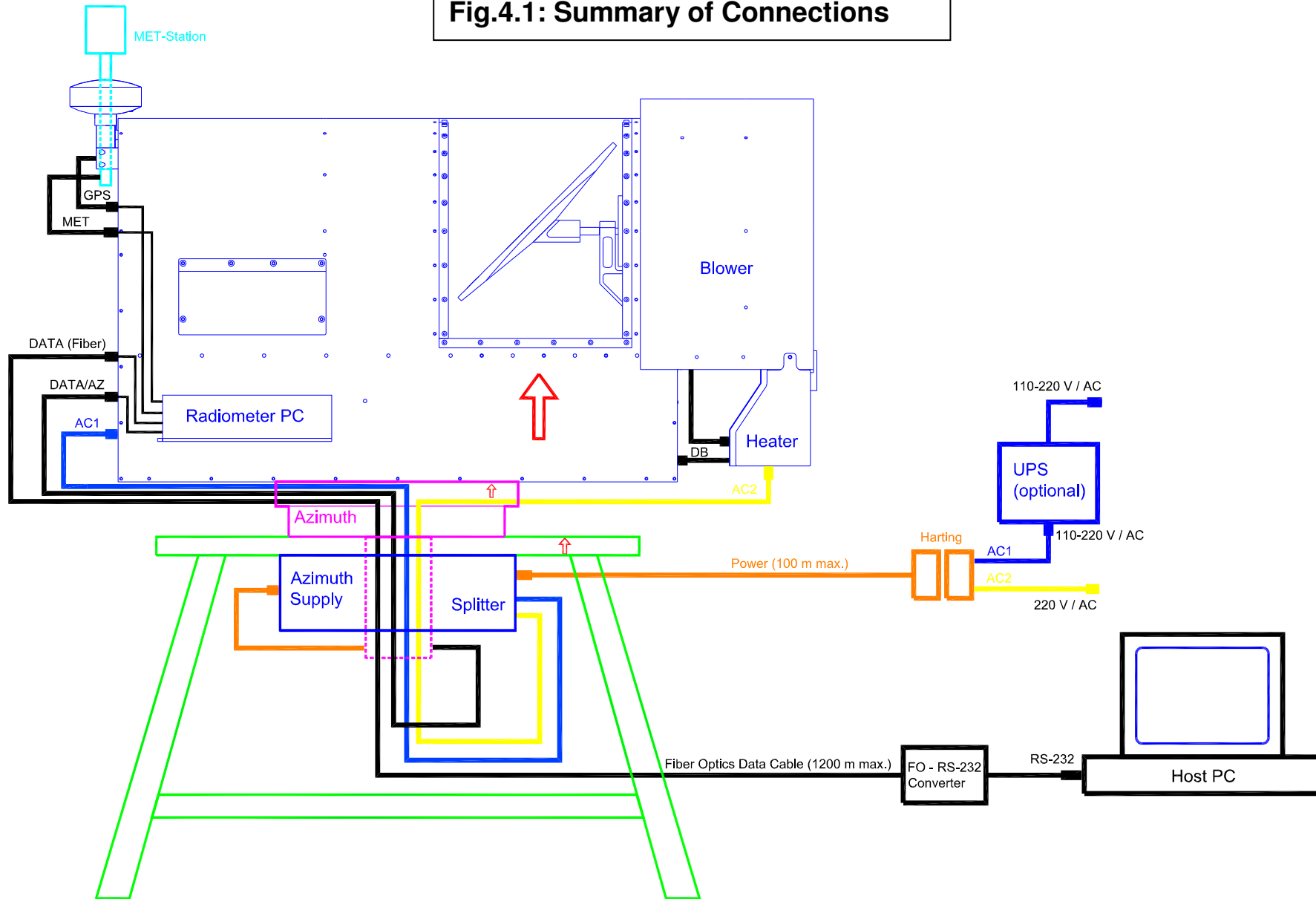

5 Radiometer dimensions

