

RADIOMETER Physics GmbH

Radiometer Physics GmbH
Meckenheim, Germany

*Microwave, sub-mm, THz
Turn-key radiometers, space technology Components,
design, scientific expertise*

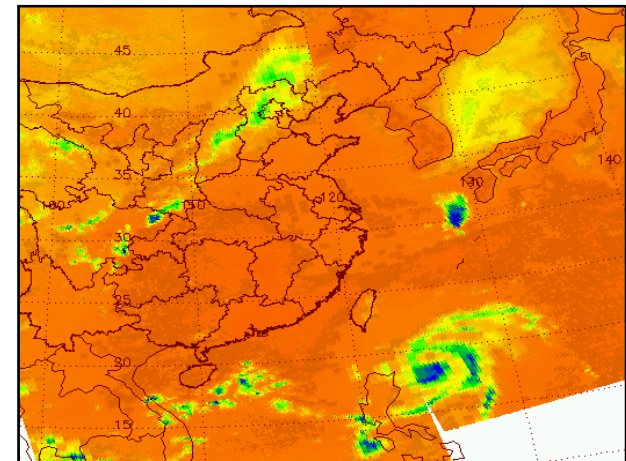
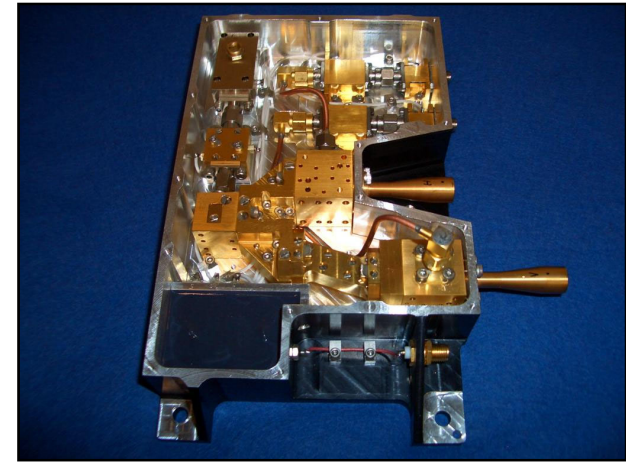
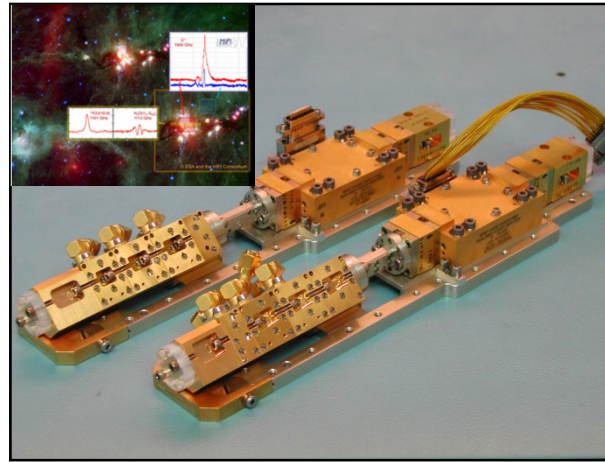
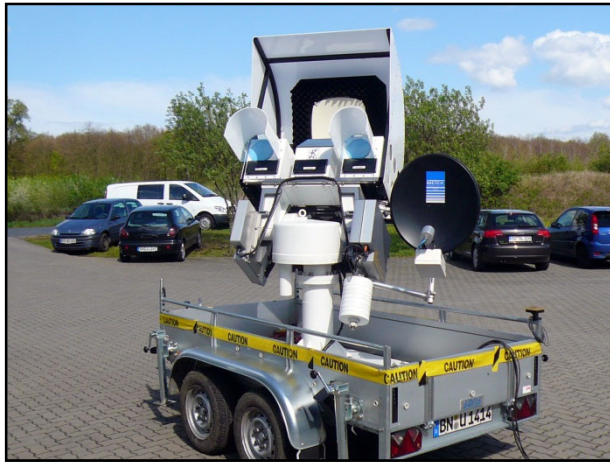

- Founded 1973 by Dr. P. Zimmermann
- 40 (+) employees
- Design / fabrication of MW-radiometers (mm, sub-mm)
- Development of radiometer sub-systems (oscillators, mixers, waveguide components, planar networks, amplifiers, optics, etc.)

Active in the following fields:

- Radio Astronomy
- Plasma Physics
- ESR Spectroscopy
- **Remote Sensing**
- Space borne radiometers
- Network Analyzer Extensions



RPG GmbH Organization

Company Management

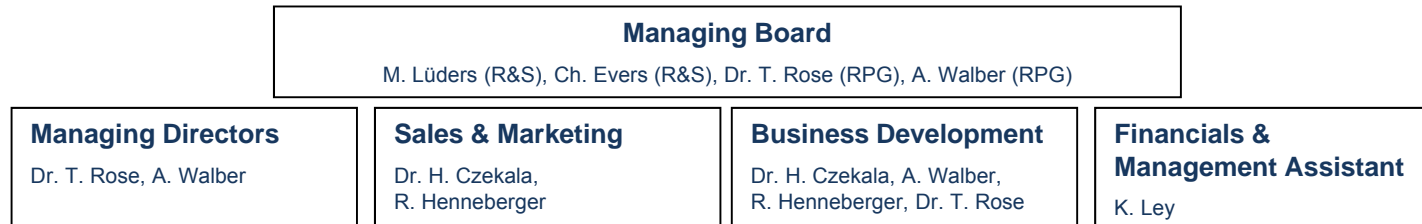

Business Divisions

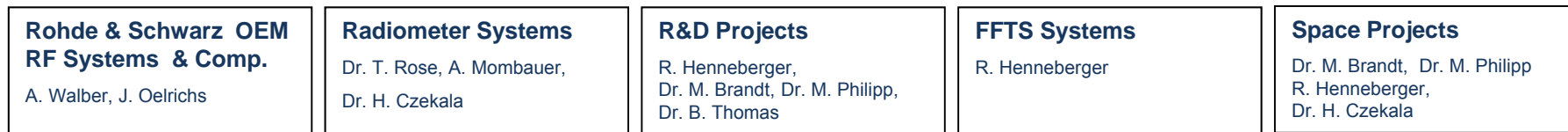

Operations & Activities



Fields of activity (2010)

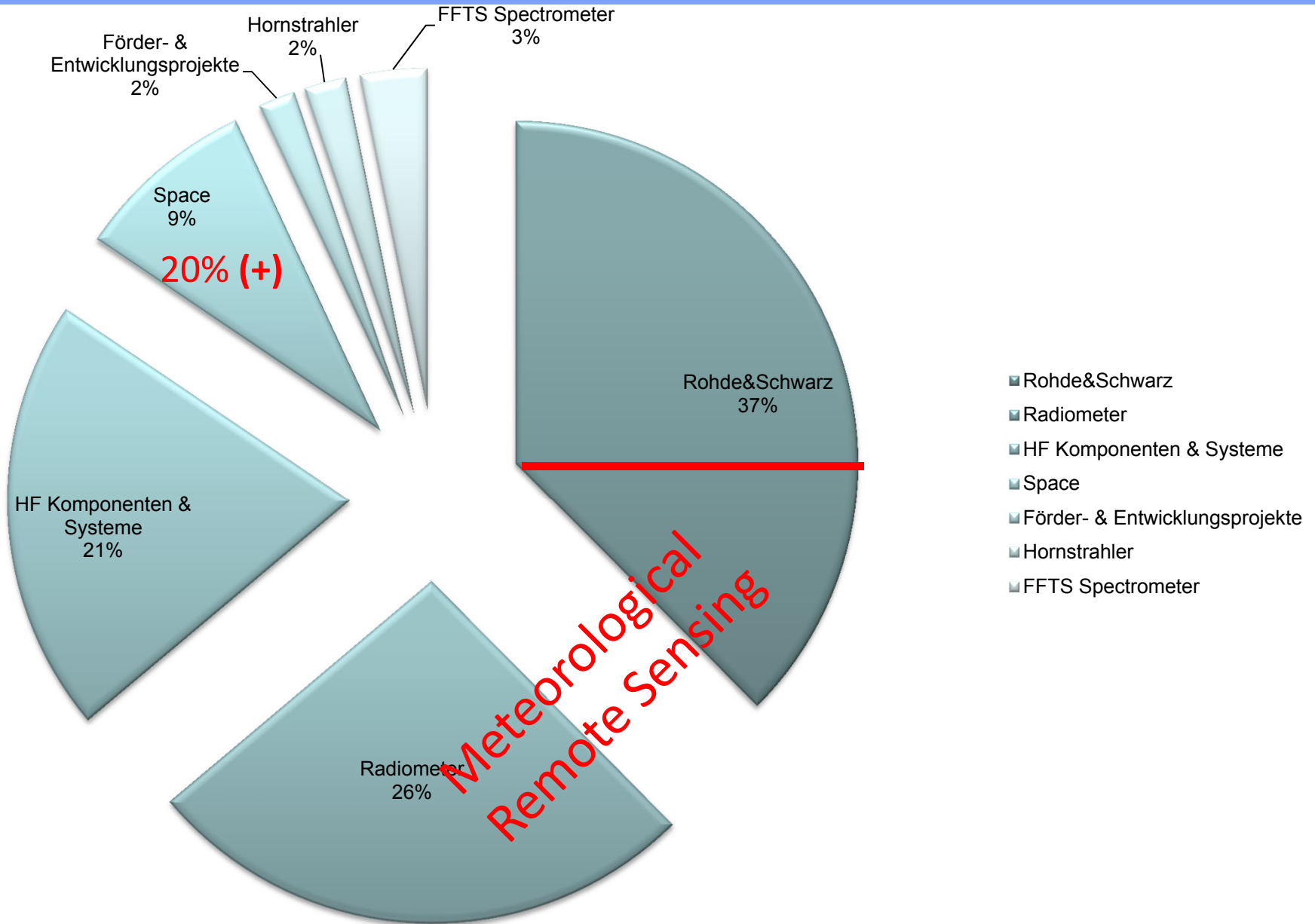

Technology to Product

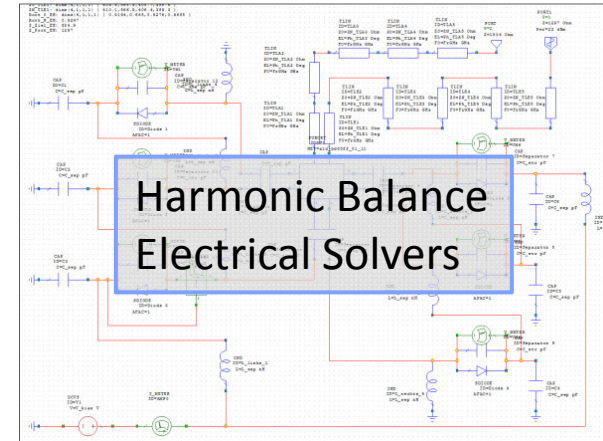
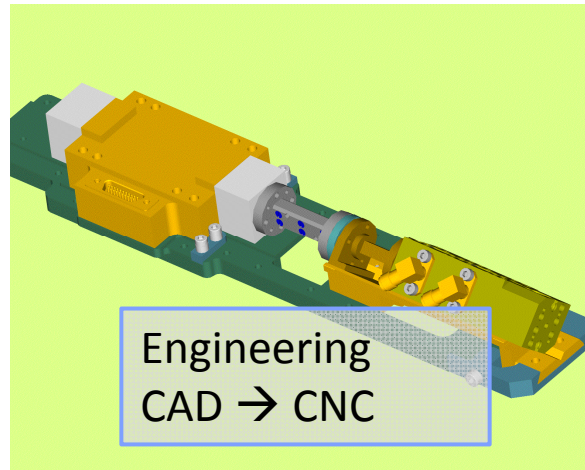
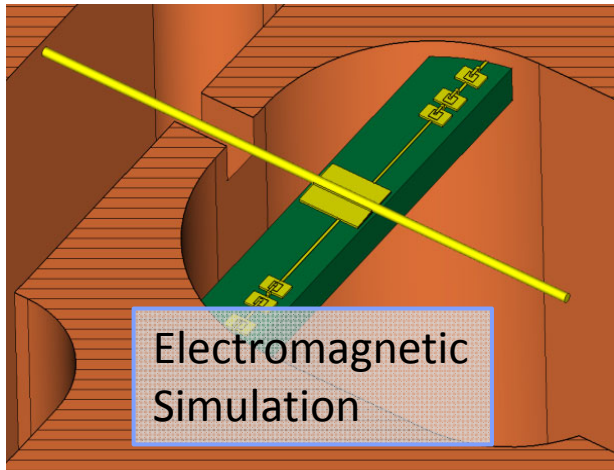

Knowledge, experience, precision and quality

- Design
- Development
- Manufacture
- Integration and Test

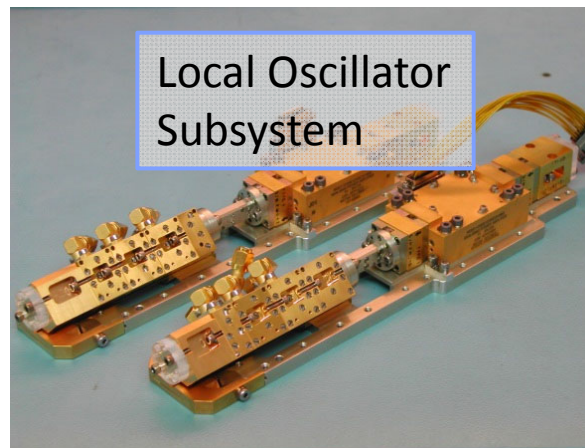
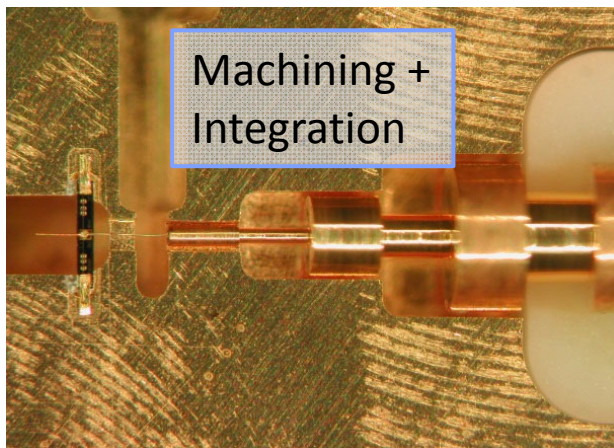

Simulation and Design Capabilities

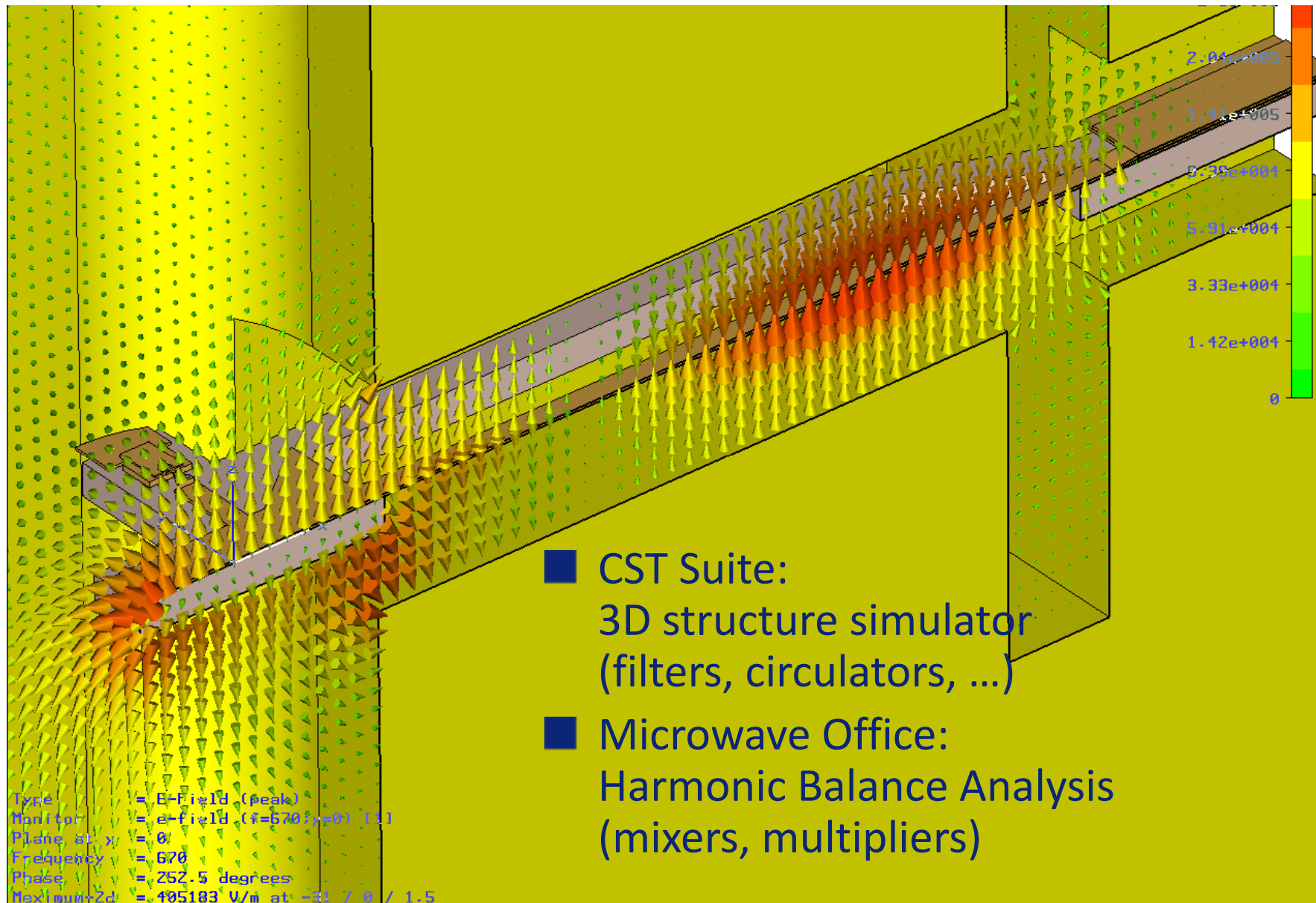

Amplifier bonding (clean room, space standards)

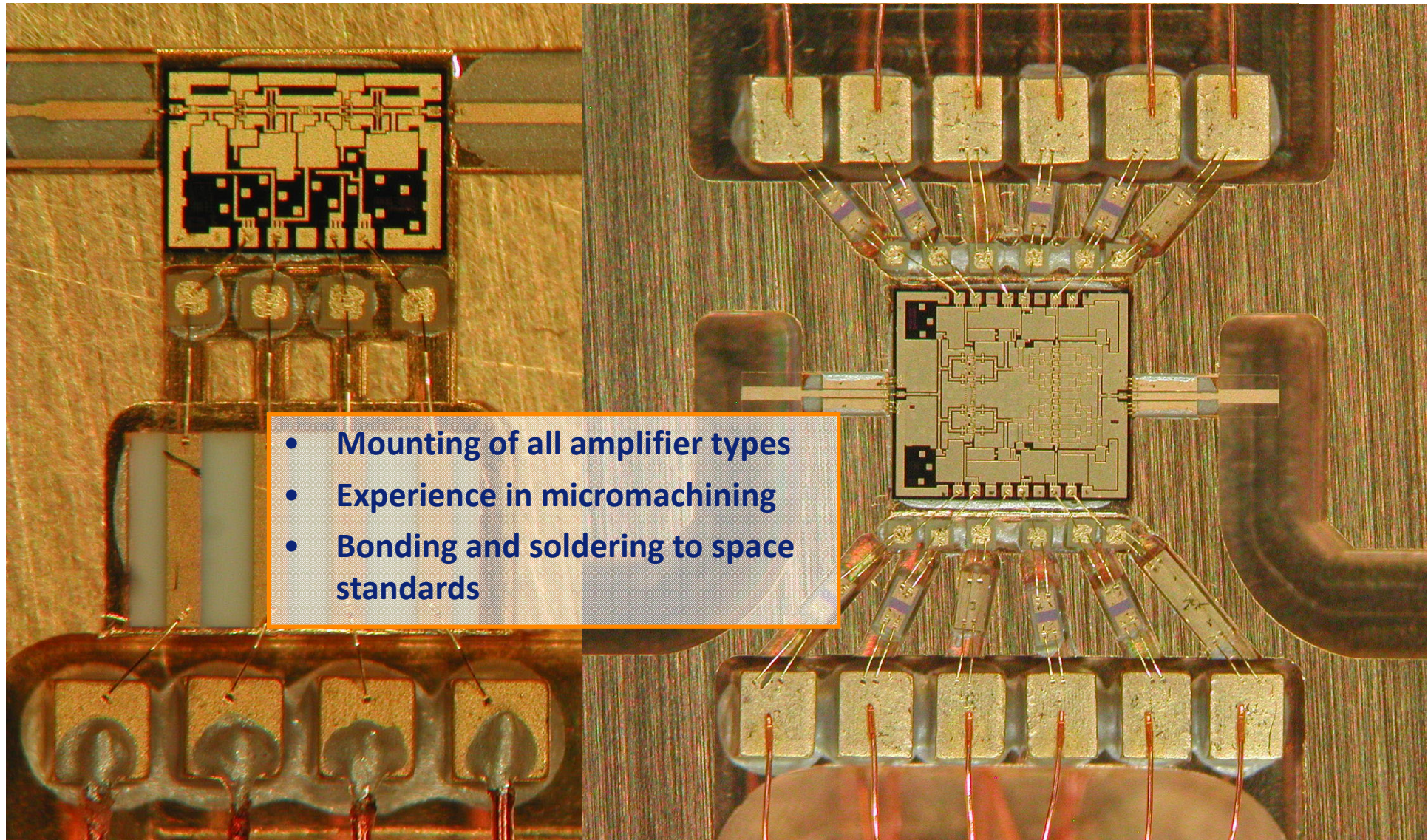

Schottky Mixer and Multiplier Improvements

- Planar technology
- Discrete Schottky devices
- Semi-integrated and full integrated structures

Two collaborations:

- STFC/RAL, UK
- ACST, Germany

Mandatory improvements for 800 to 1000 GHz circuit mountings:

- Reduced C_{j0}
- Reduced C_{str}
- Smaller size

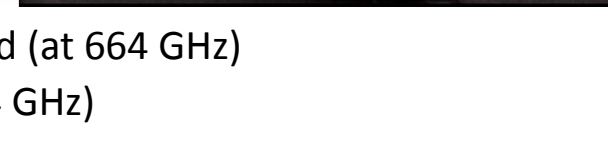
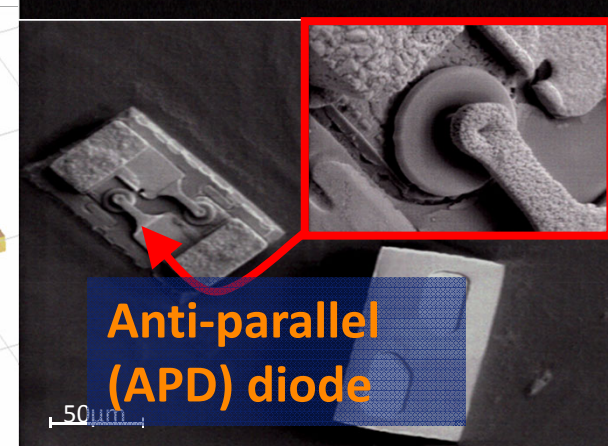
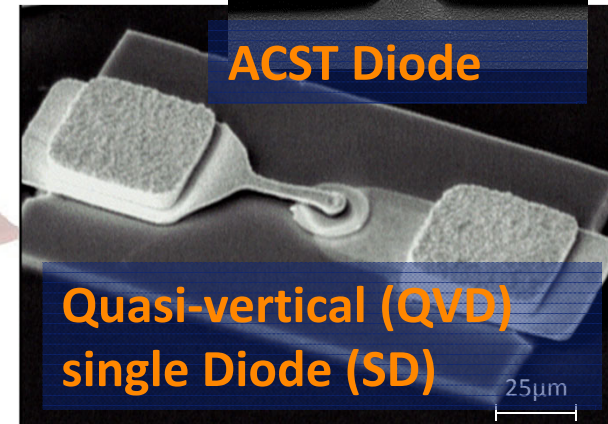
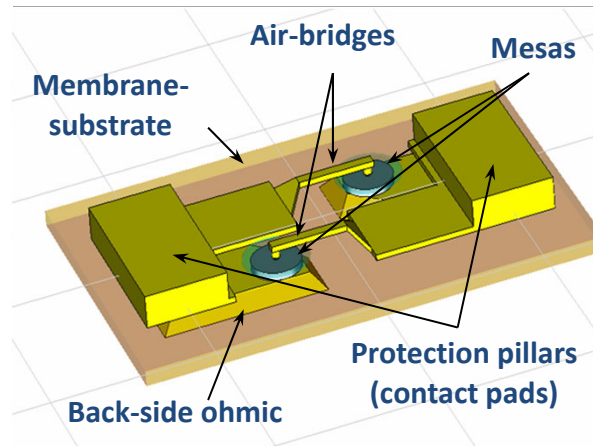
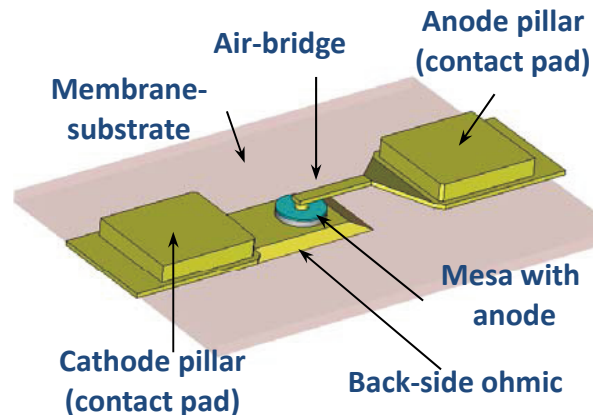

ESTEC Contract 22032/08/NL/JA: Sub-Millimeter Wave Receiver Front-End (at 664 GHz)

ESTEC Contract 21628/08/NL/GLC: Integrated Schottky Structures (at 664 GHz)

Sample pictures

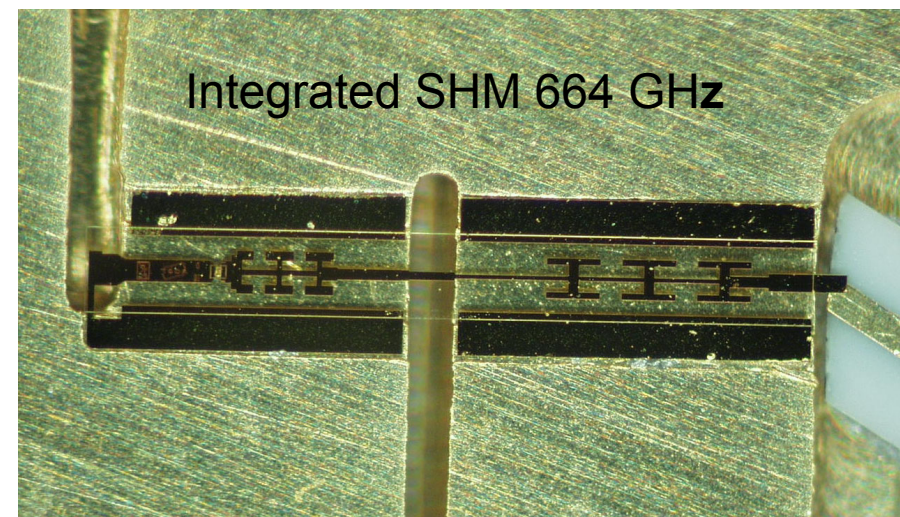
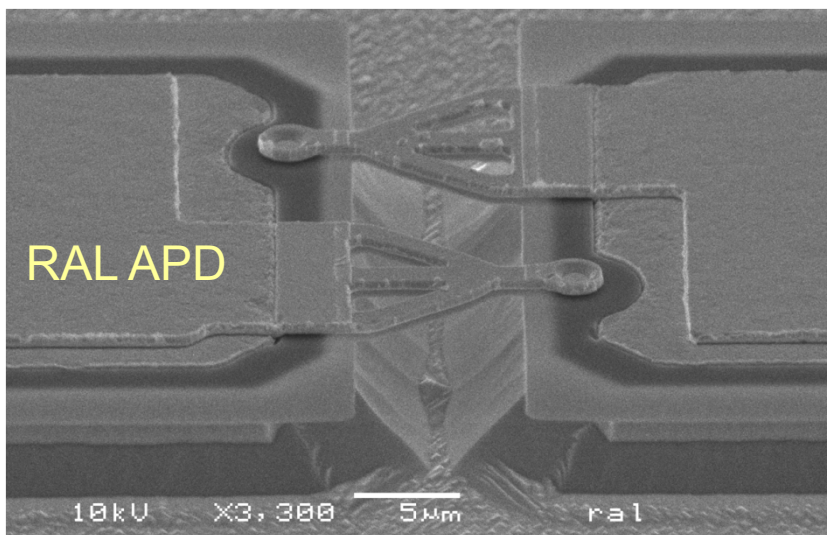
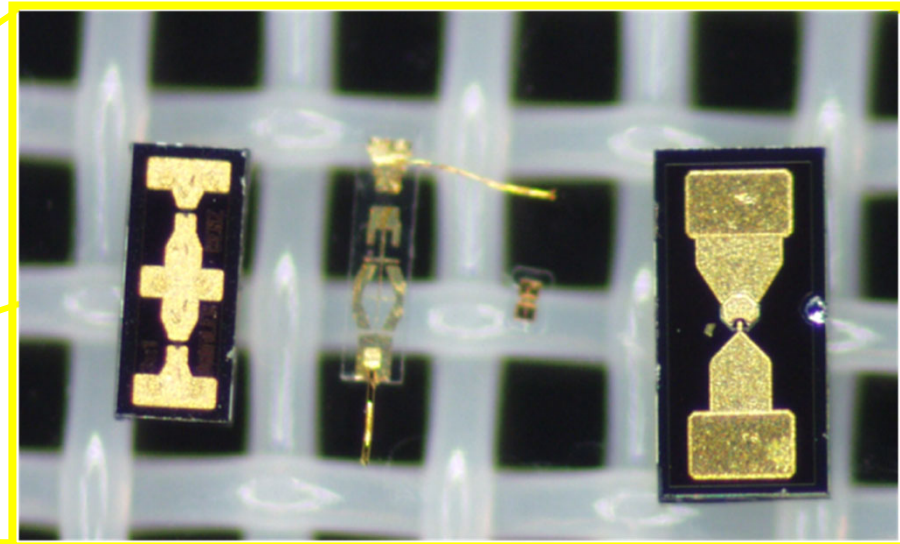
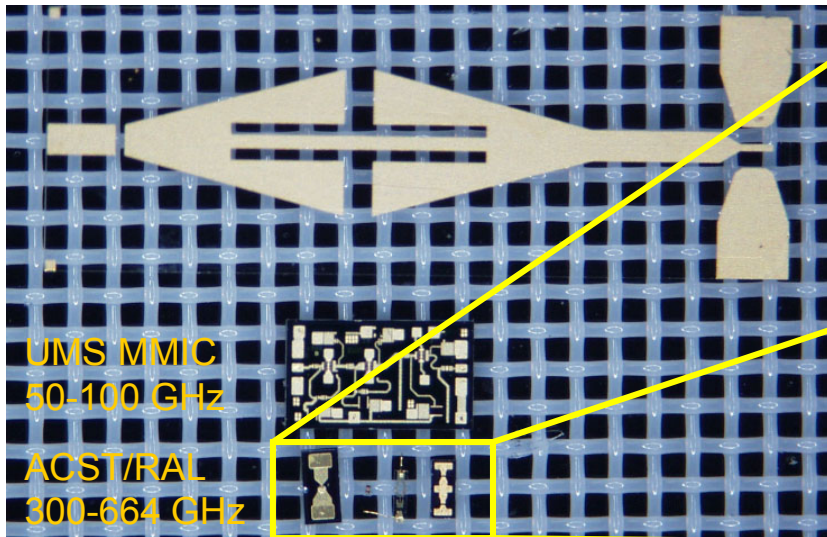

Improved Schottky Diodes: VNA Extender

50 – 75 GHz
60 – 90 GHz
75 – 110 GHz
90 – 140 GHz
110 – 170 GHz
140 – 220 GHz
220 – 325 GHz
325 – 500 GHz
(500 – 750 GHz)

OEM
Network Analyzer
Frequency
Extenders
for
Rohde & Schwarz



Courtesy of Rohde & Schwarz



Improved Diodes: RPG sub-harmonic mixers

Art.-No.	RF Range [GHz]	DSB-Noise Temperature	Conversion Gain (DSB)	IF-Bandwidth	Required LO Power	Waveguide LO	Waveguide RF
SHM118	104-132	500 K	-5 dB	> 16GHz	6 dBm	WR15	WR8
SHM137	110-165	500 K	-6 dB	> 20 GHz	4-7 dBm	WR12	WR6.5
SHM150	134-167	450 K	-6 dB	> 16 GHz	2 dBm	WR12	WR6.5
SHM183	167-200	430 K	-4 / -5 dB	> 16 GHz	4 dBm	WR10	WR5.1
SHM220	185-230	500 K	-6 dB			WR10	WR5.1
SHM280	265-295	700 K	-7 dB		WR6.5	WR3.4	
SHM300	275-330	900 K	-7 dB		WR6.5	WR3.4	
SHM340	310-360	1000 K	-6 / -7 dB		WR6.5	WR2.8	
SHM424	400-440	1100 K	-7/ -8 dB		WR4.3	WR2.2	
SHM664	644-680	1600 K	-8 dB		WR3.4	WR1.5	

Receiver technology – 183 GHz example

183 GHz feeds and sub-harmonic mixers for ALMA-WVR

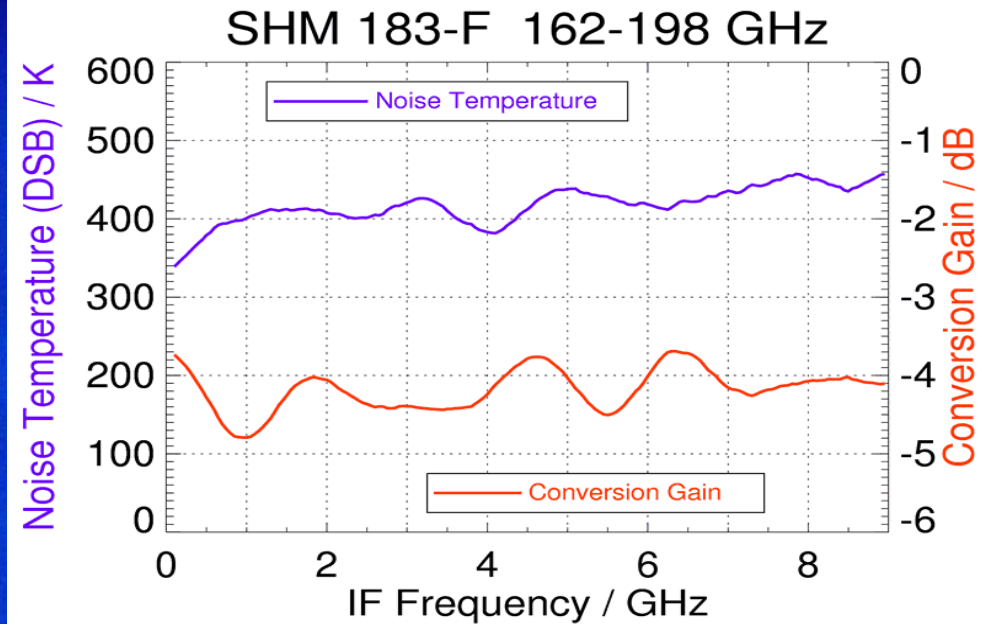

- Best 183 GHz receivers available
- Built in larger numbers
- Noise-injection calibration @183 (RPG only manufacturer world wide)
- All ALMA water vapor radiometers equipped with RPG mixers and feeds

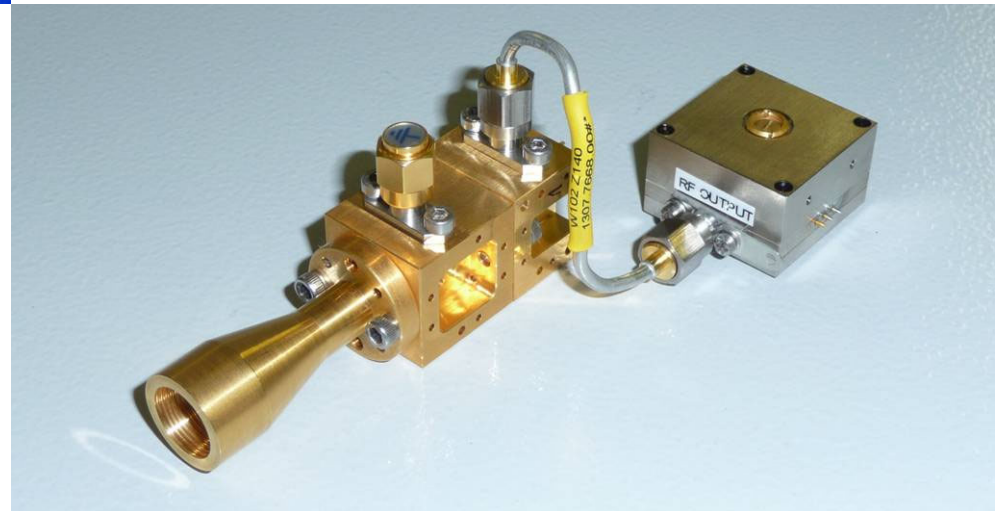

Space Products

Integrated Structure SHM

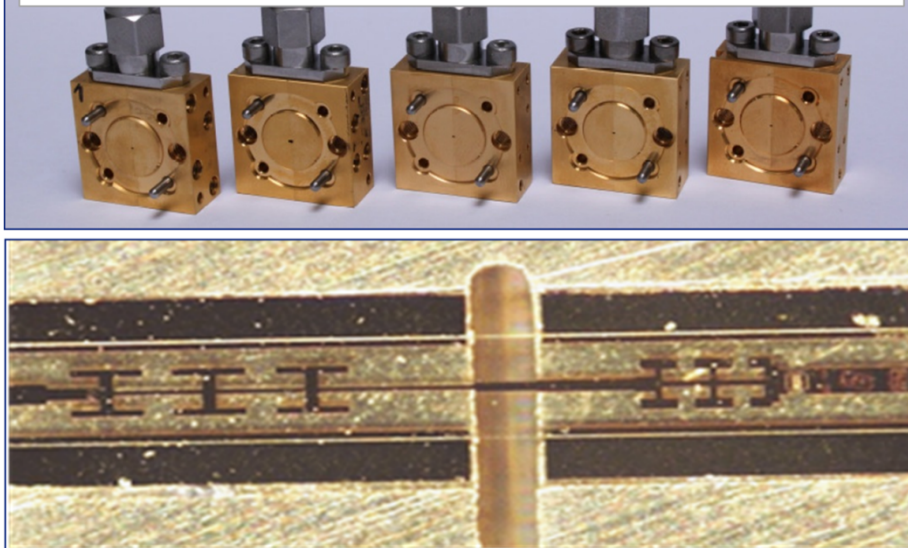

664 GHz Receiver

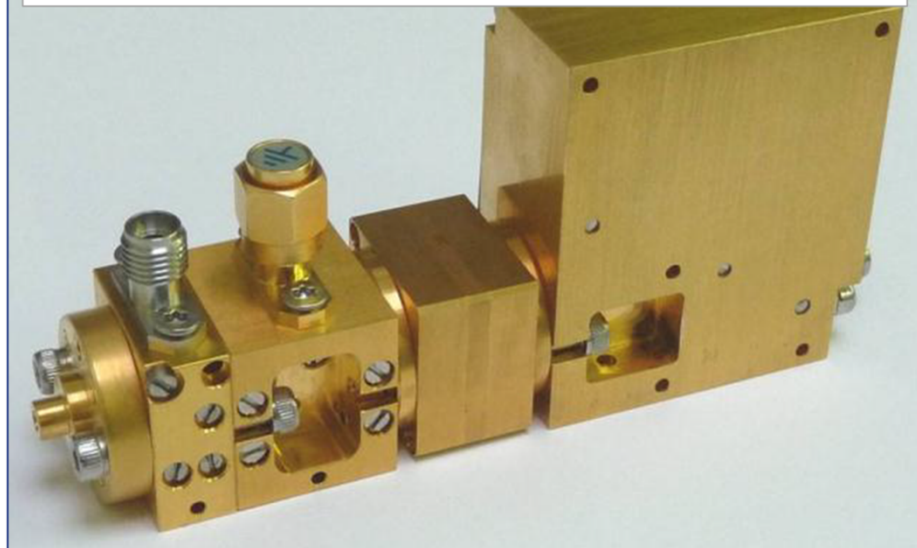

Herschel/HIFI 1100 GHz LO

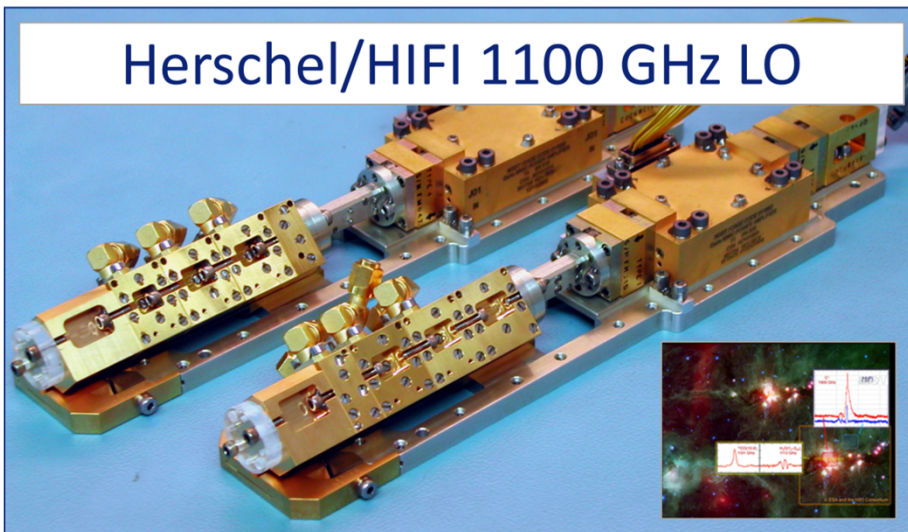

Examples of RPG contributions:

- MLS LO sources
- ODIN LO sources, mixers
- HIFI (Herschel) LO, up-converter
- JEM/SMILES LO at 360 GHz, PLL
- HY-2, FY1 – FY4 FE Imager/Sounder (MW sounder)
- SAPHIR (MW Imager)
- MADRAS (MW Imager)

Space Products (II)

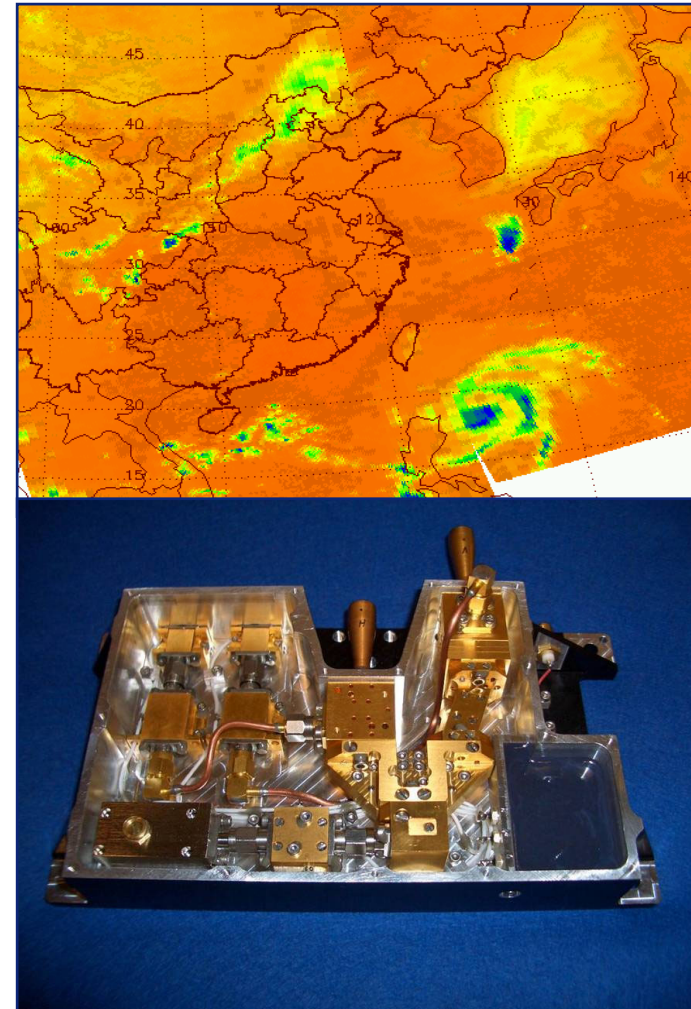
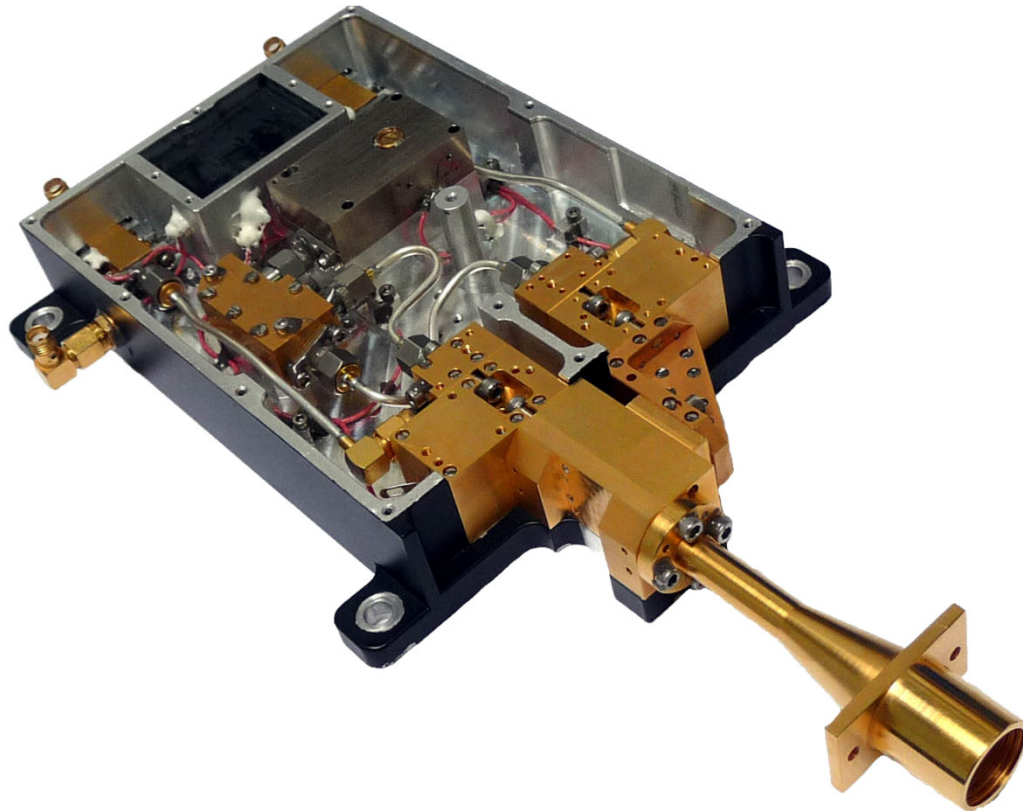

Space qualified front ends (China, FY-3):

- 90 GHz dual polarized receiver
OMT + LNA + (either Direct Detection or Heterodyne)
- 150 GHz dual polarized receiver: OMT + SHM

ISMAR 664 GHz Receiver

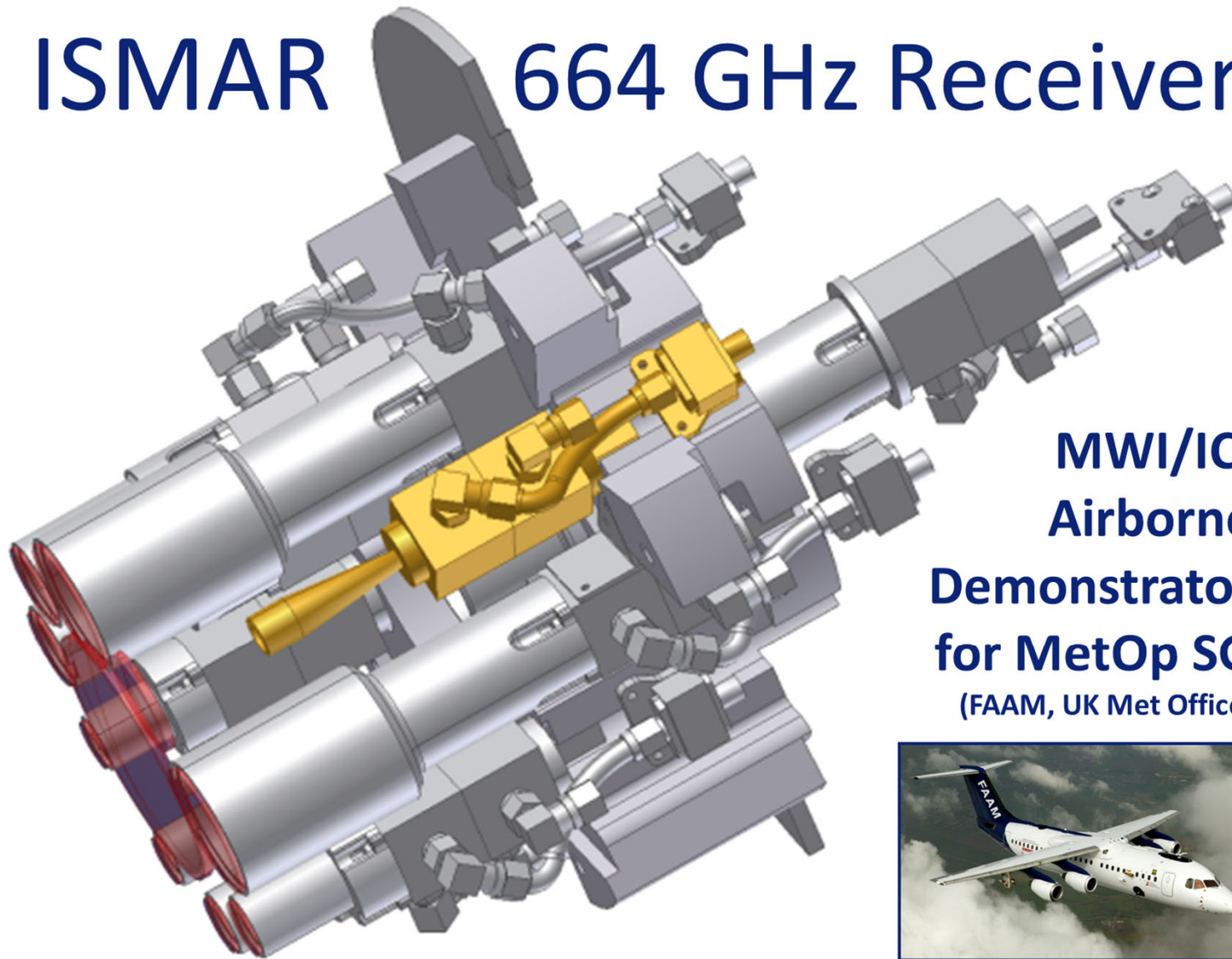

**MWI/ICI
Airborne
Demonstrator
for MetOp SG
(FAAM, UK Met Office)**



Space Products (III)

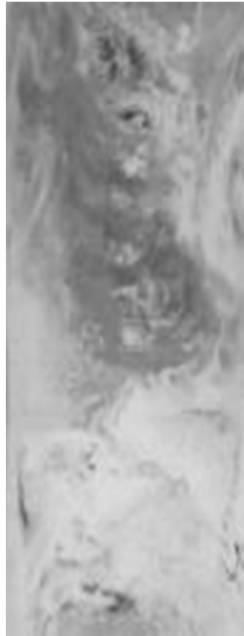
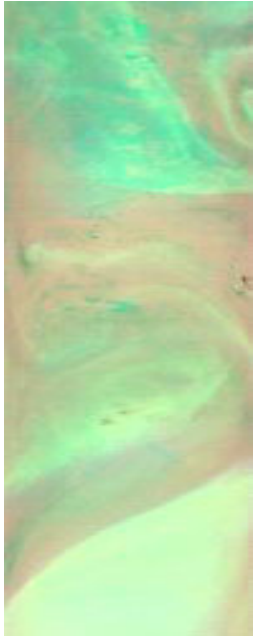

Space qualified front ends:

- 183 GHz (4 channels) for sensitive water vapour detection
- 90 GHz dual polarized receiver
- 150 GHz dual polarized receiver

Auto-Calibration Receivers

- Noise injection calibration up to 200 GHz
 - 7.000 K signal at 183 GHz with stable noise diode (15 dB ENR)
- Magnetically switched isolators: Dicke switching up to 150 GHz with low insertion loss (≤ 1.0 dB)
 - Fast switching with low currents (small thermal effects, 100 mA, 0.5 V)

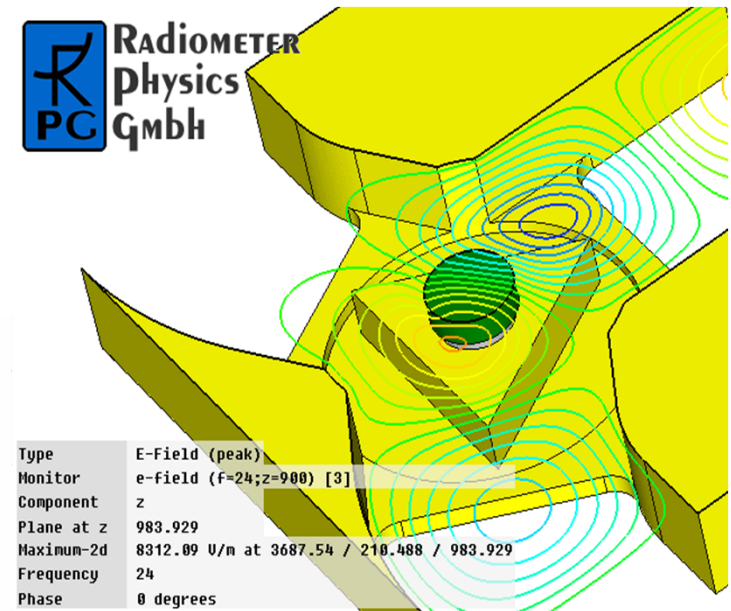
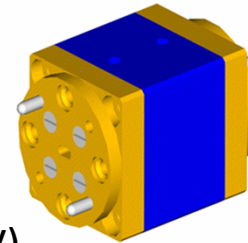

- ➔ Allan Variance Stability: 4.000 s
- ➔ Less dependent on external calibration targets (LN2)!

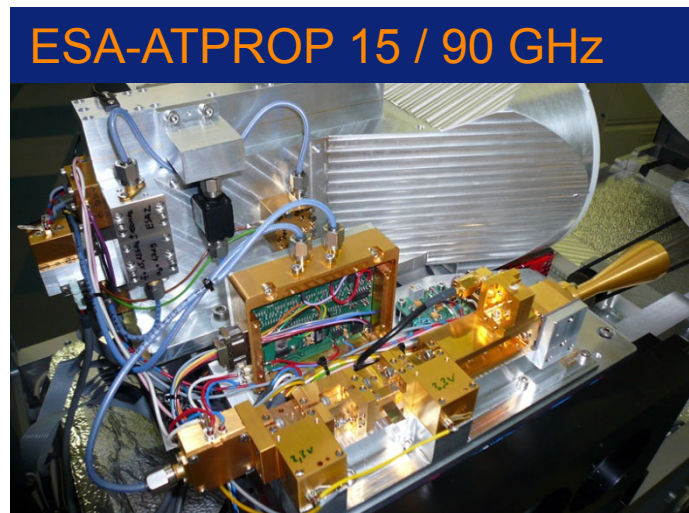
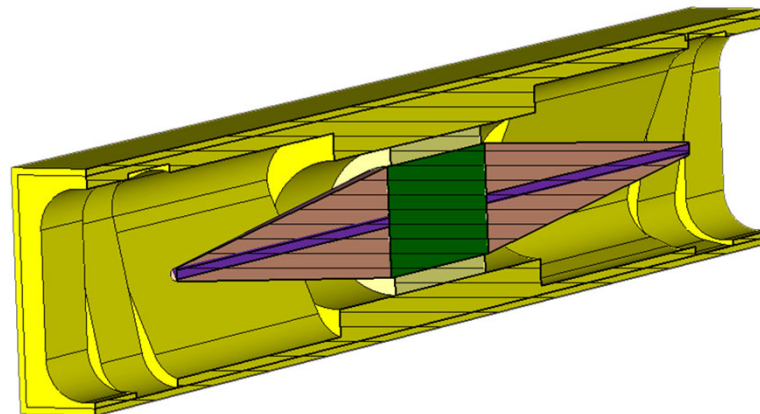

Sub-mm imaging receivers

- **One-Pixel and Multipixel Receiver:**

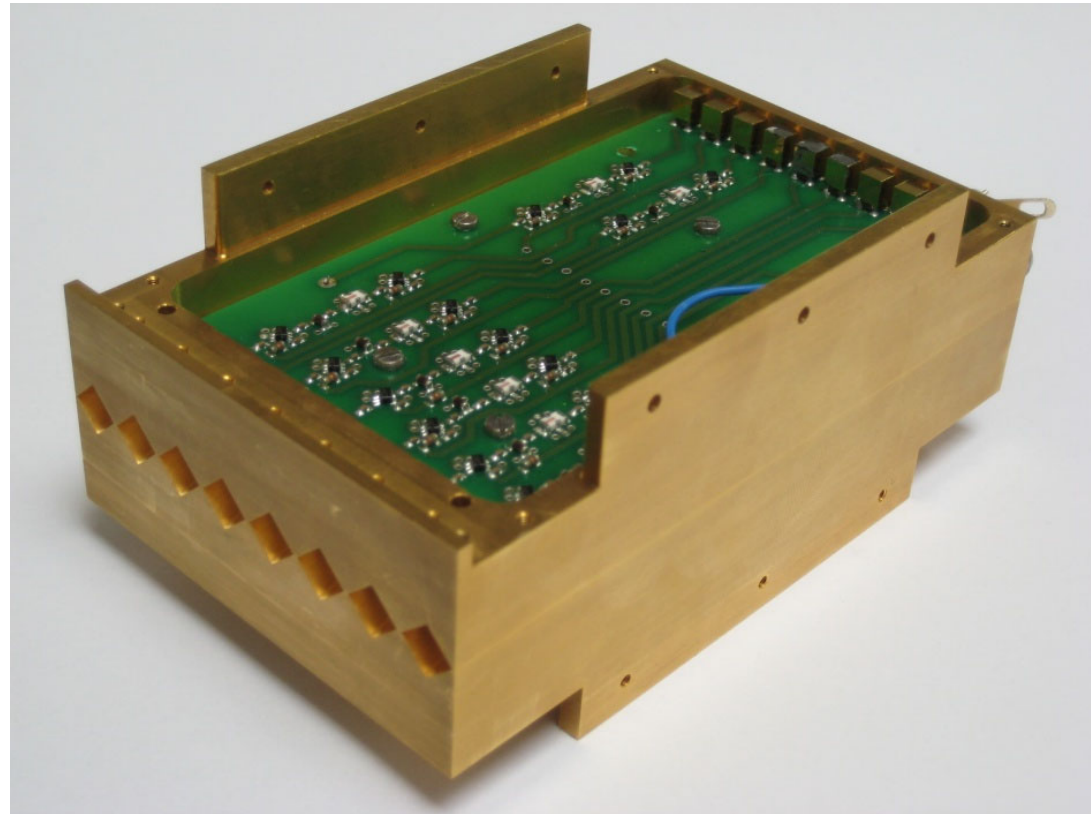

- **FMCW Radar 75 to 325 GHz**
- **CW Radar**
- **8-Pixel Array 230-320 GHz (ESA) and 8-Pixel Array 812 GHz,**
- **4-Pixel Array 183 GHz**
- **Imaging, Security, Material Analysis, Science**

Antenna Measurement Solutions



Transmit / Receive Systems, Spectrum Analyzer Solutions:

■ Full-band

50-75 GHz	60-90 GHz	75-110 GHz	110-170 GHz	140-220 GHz
170-260 GHz	220-325 GHz	260-400 GHz	325-500 GHz	

■ High Dynamic Receivers available at

90 GHz	183 GHz	220 GHz	324 GHz
502 GHz	640 GHz		

■ For compact ranges (antenna measurement facilities, phase + amplitude)

Radiometer Products

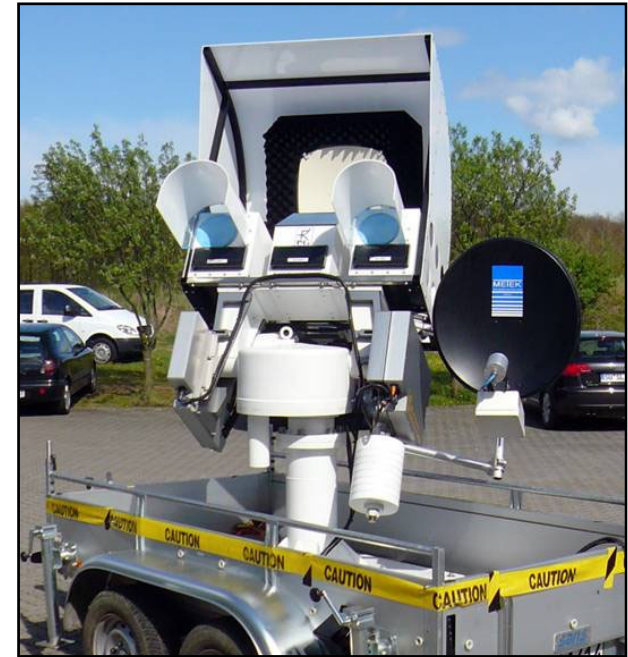
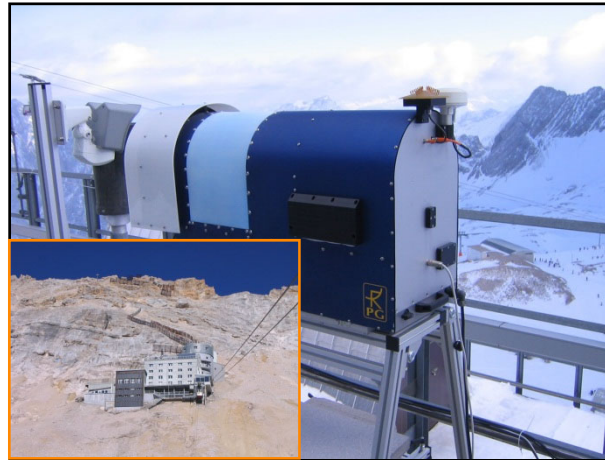

Approx. 25 standalone multi-channel radiometers per year

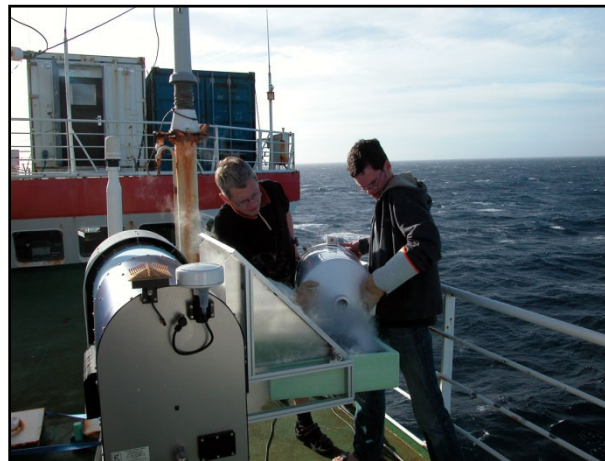

Radiometers Deployments



Lampedusa, Italy
(humid, hot, salty)



Dome-C, Antarctica
(3.300m, -25 to -80 °C)

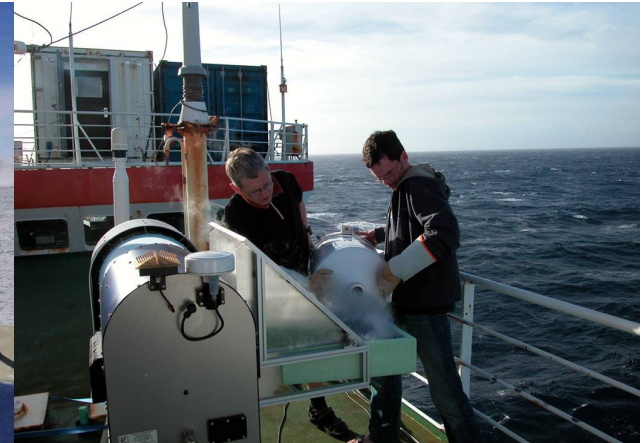

Research Vessel "Polarstern"
(Atlantic Ocean)



ALMA site, Chile
(5.500m above sea level)



Zugspitze, Germany
(2.800m, -35 °C, 250km/h wind)



AMMA campaign, Benin
(West-Africa, hot climate, dust)

Radiometers Deployments

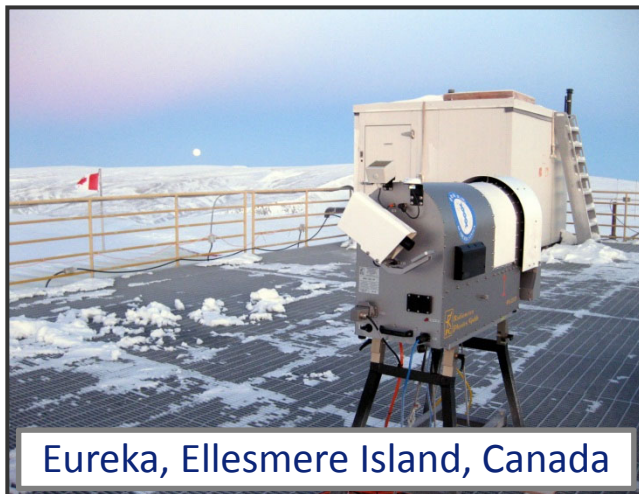
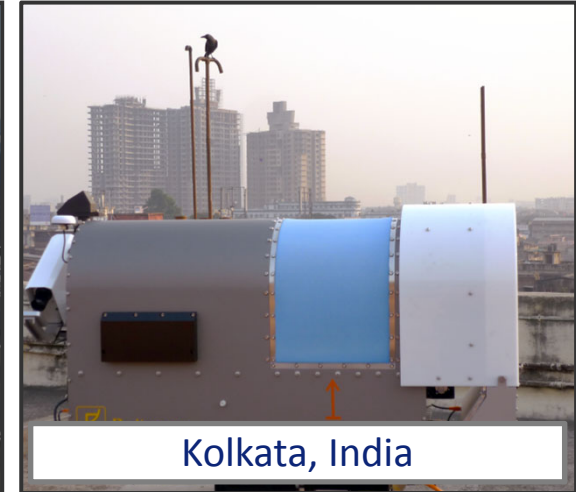

MWSC: Scintillometer @160 GHz for Latent Heat Flux

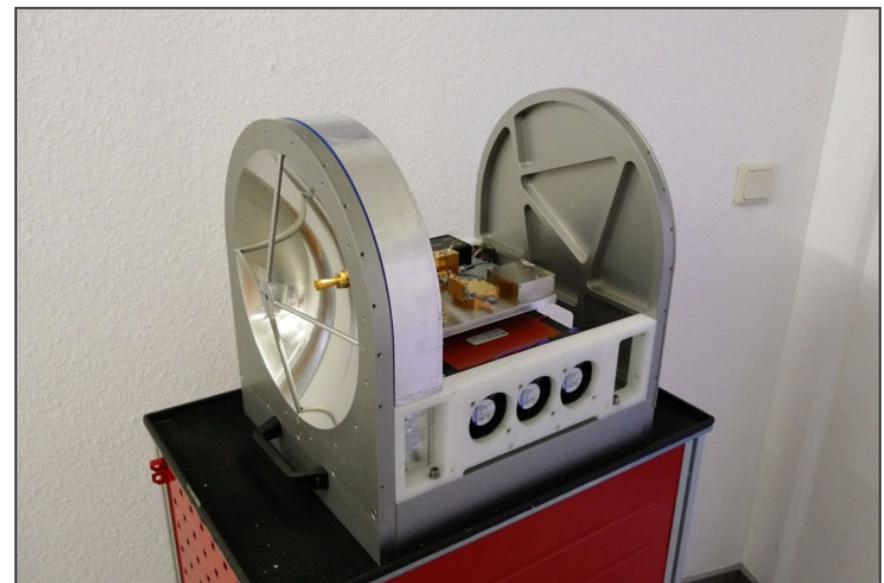
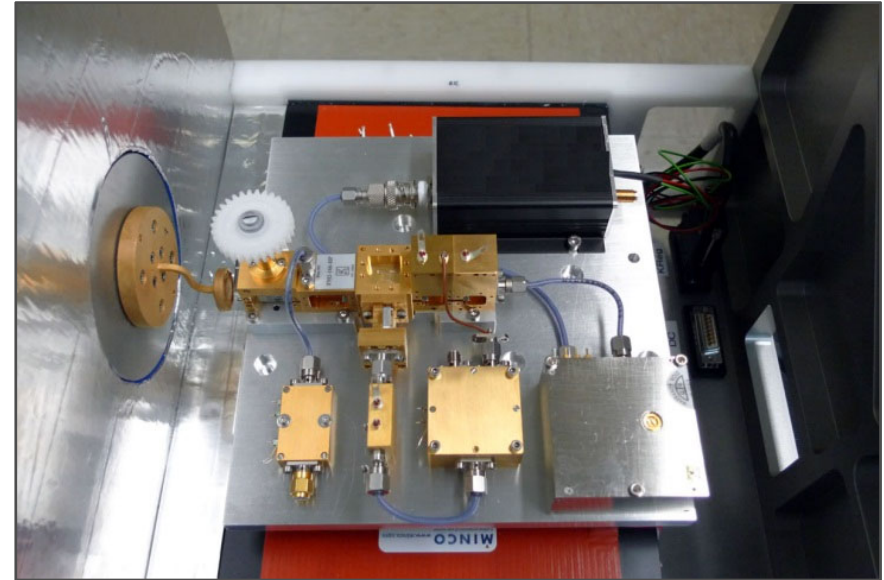
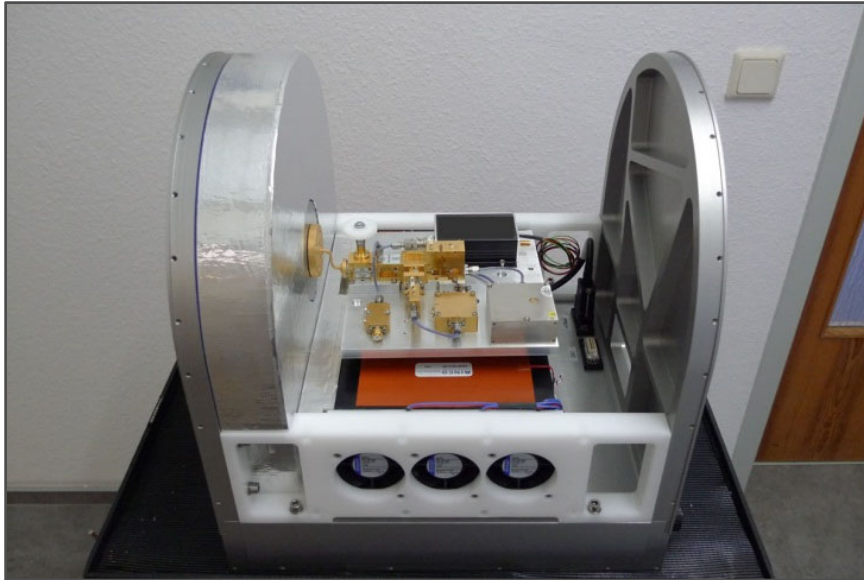

MWSC Integration

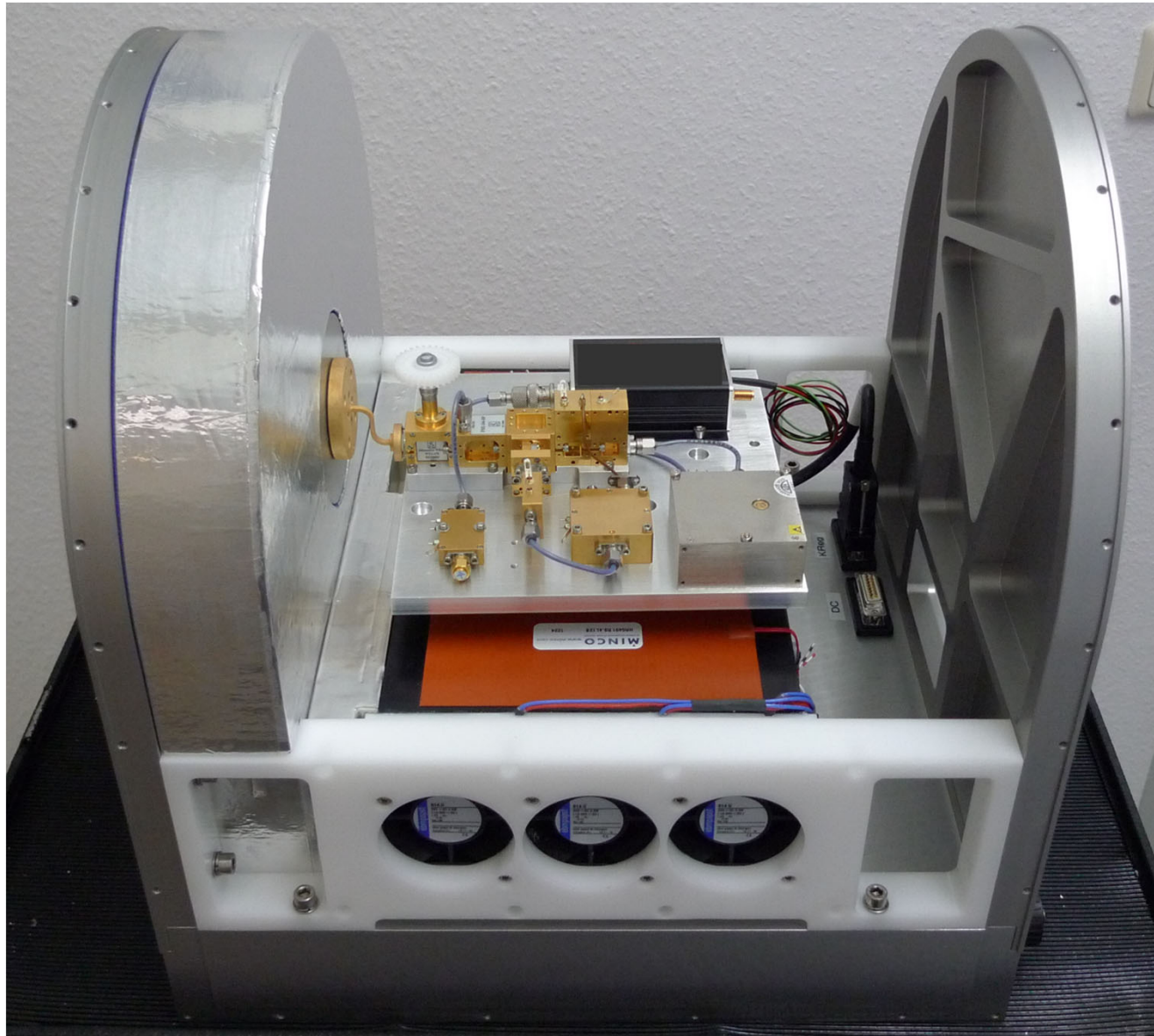

RPG-FMCW-94

RPG-FMCW-94-DP

A Cloud Radar by RPG

- Frequency Modulated, Continuous Wave, 94 GHz
- Low mode for fog, high mode up to 12 km
- Re-using RPG technology from Tx/Rx systems and network analysis
- Re-using instrument infrastructure (housing, steering, control, data processing) from microwave radiometers
- Supported by Fraunhofer Institute for RF Technology and Radar (FhG-FHR, Wachtberg, Germany, formerly FGAN)

Availability: Mid of 2013

RPG-FMCW-94 Specifications (I)

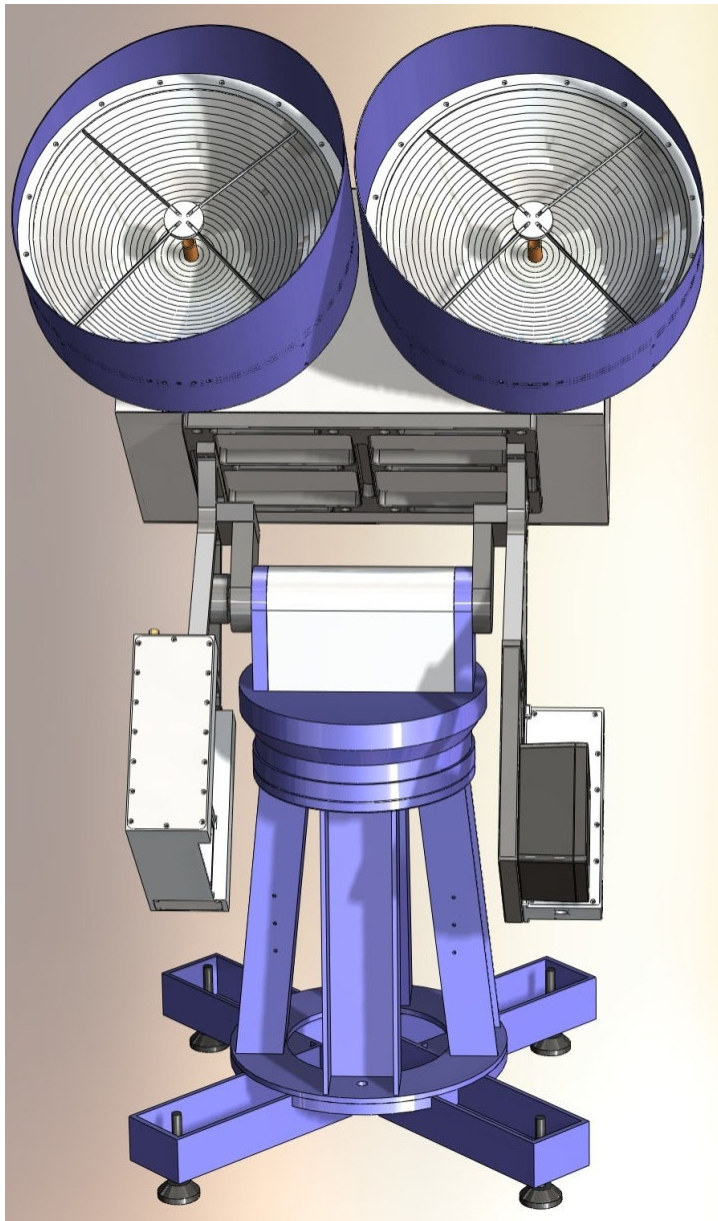

Operating Frequency:	94 GHz +/-150 MHz
IF Range:	0.5 MHz to 1.3 MHz
Continuous Power:	500 mW (Solid State)
T/R Type:	Bi-static
Antenna Diameter:	500 mm
Gain:	52 dB
Chirp Rate:	100 / sec
Chirp Variations:	7
Passive LWP Channel:	89 Ghz (optional)
Dynamic Range:	-100 dBz to +20 dBz

RPG-FMCW-94 Specifications (II)

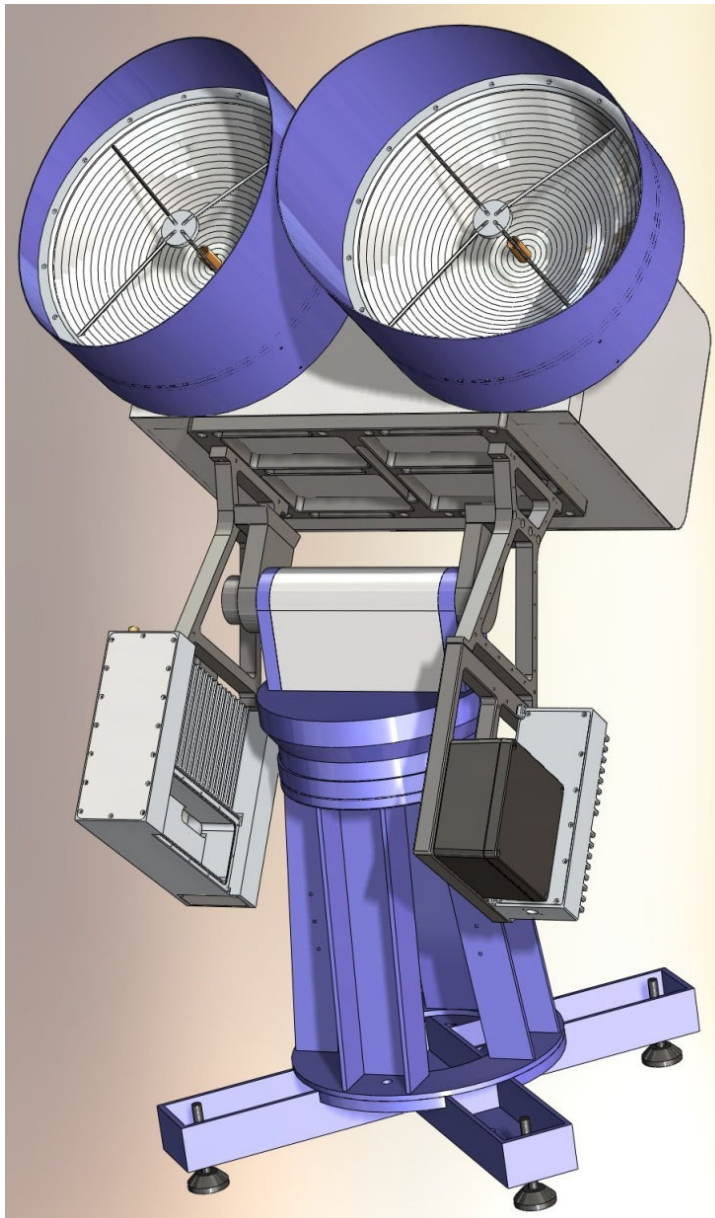

Ranging:	10 m to 12 km
Sampling Rate:	1 / 4 seconds
Vertical Resolution:	1 m (r: 10m - 600 m) 2 m (r: 0.6 – 1.0 km) 4 m (r: 1.0 – 2.5 km) 8 m (r: 2.5 – 5.0 km) 16 m (r: 5.0 – 12.0 km)
Doppler Resolution:	+/- 15 cm/sec
Polarisation:	v / h (optional)

Availability: Mid of 2013

Possible extensions by

- Additional frequencies
- Passive microwave channels
- Polarisation options

Reference Customers (selected)

- ESA-ESTEC
- NASA/JPL
- EADS-Astrium
- Thales-Alenia Space
- SRON (Netherlands)
- CNES (France)
- DLR (Germany)
- Chinese Space Agency (CAS, CSSAR, ...)
- IRAM
- NIST (National Institute for Standards, USA)
- PTB (German institute for standards)
- CNRS (France)
- ESO (European Southern Observatory)
- Rohde & Schwarz
- AB-millimetre
- Aerospace Corporation (USA)
- US Air Force, AFRL Research Labs
- ROKAF (South-Korean Air Force)
- ARM (Atmospheric Radiation Monitoring, USA)
- KMA (Korean weather service)
- CNRS (France)
- UK Met Office
- KNMI (The Netherlands weather service)
- Meteo Swiss (Switzerland)
- Polish weather service
- Numerous Universities world wide
- AWI Alfred Wegener Institute f. Polar Research
- Numerous Universities and Research Institutions